

DIXON
ENGINEERING & INSPECTION SERVICES
FOR THE COATING INDUSTRY

4811 S. 76th Street
Suite 109
Greenfield, WI 53220
Telephone: (414) 529-1859
Fax: (414) 282-7830

February 6, 2025

Mr. Adam Florin
City of Wauwatosa
11100 W. Walnut Road
Wauwatosa, WI 53213

Re: 2,500,000-Gallon Toroellipse Repainting Project Progress Payment Recommendation

Dear Mr. Florin:

Dixon Engineering, Inc. has reviewed the pay request package submitted to our office (electronically). The pay request covers the work dates starting 09-04-2024 through 10-18-2024. Included in the pay package are the following items.

- Contractor’s application for payment
- O&J Coatings, Inc. Waiver of Lien
- Tnemec Waiver of Lien
- Taylor Way Waiver of Lien

Dixon Engineering, Inc. has verified and concurs with the contractor’s final pay request, based on the actual field measurements as documented in our daily field inspection reports (FIR). A summary for the final pay request is provided below.

Payment Summary:

Contract award amount.....	\$986,000.00
Change order amount.....	(-\$5,000.00)
Previous payments amount.....	\$822,700.00
Total amount due contractor this pay request (Final).....	\$158,300.00

Please don’t hesitate to contact me if you have any questions regarding this pay request.

FOR DIXON ENGINEERING, INC.,

Kayla Mulcahy
Project Manager

Contractor's Application for Payment No. 2

Application Period: 08/13/2024 TO 2/3/2025		Application Date: 2/3/2025	
To (Owner): CITY OF WAUWATOSA, WISCONSIN	From (Contractor): O&J COATINGS, INC.	Via (Engineer): DIXON ENGINEERING, INC.	
Project: 24-55 Burleigh Water Tower Rehabilitation	Contract: 8958859		
Owner's Contract No.: 8958859	Contractor's Project No.: 8958859	Engineer's Project No.: 8958859	

**Application For Payment
Change Order Summary**

Number	Additions		Deductions	
	Cost (\$)	Calendar Days	Cost (\$)	Calendar Days
1			5,000.00	
TOTALS			5,000.00	
NET CHANGE BY CHANGE ORDERS	-\$5,000.00			

1. ORIGINAL CONTRACT PRICE.....	\$	\$986,000.00
2. Net change by Change Orders.....	\$	-\$5,000.00
3. Current Contract Price (Line 1 ± 2).....	\$	\$981,000.00
4. TOTAL COMPLETED AND STORED TO DATE (Column F total on Progress Estimates).....	\$	\$981,000.00
5. RETAINAGE:		
a. 5% X _____ Work Completed.....	\$	_____
b. 5% X _____ Stored Material		_____
c. Total Retainage (Line 5.a + 5.b)		_____
6. AMOUNT ELIGIBLE TO DATE (Line 4 - Line 5).....	\$	\$981,000.00
7. LESS PREVIOUS PAYMENTS (Line 6 from prior Application).....	\$	\$822,700.00
8. AMOUNT DUE THIS APPLICATION.....	\$	\$158,300.00
9. BALANCE TO FINISH, PLUS RETAINAGE		_____
10. CALENDAR DAYS USED ON PROJECT		_____
11. CURRENT CONTRACT DAYS (Days Bid + Net Change)		_____
12. PROJECT DAYS REMAINING (Line 11 - Line 10)		_____

Contractor's Certification

The undersigned Contractor certifies, to the best of its knowledge, the following:
 (1) All previous progress payments received from Owner on account of Work done under the Contract have been applied on account to discharge Contractor's legitimate obligations incurred in connection with the Work covered by prior Applications for Payment;
 (2) Title to all Work, materials and equipment incorporated in said Work, or otherwise listed in or covered by this Application for Payment, will pass to Owner at time of payment free and clear of all Liens, security interests, and encumbrances (except such as are covered by a bond acceptable to Owner indemnifying Owner against any such Liens, security interest, or encumbrances); and
 (3) All the Work covered by this Application for Payment is in accordance with the Contract Documents and is not defective.
 (4) Project days remaining reflects true, full, and accurate accounting of work days utilized and remaining in accordance with the Contract Documents as of the date of signature. No adjustments to "current contract days" for previous time impacts will be made unless identified on a pending change order, and reflected on line 12a.

Contractor Signature

By:  Date: 2/3/2025

Payment of: \$ _____ \$158,300.00
 (Line 8 or other - attach explanation of the other amount)

is recommended by: *Kayla Mulcahy* February 6 2025
 (Engineer) (Date)

Payment of: \$ _____ \$158,300
 (Line 8 or other - attach explanation of the other amount)

is approved by: *Adam Florin* 2/12/2025
 (Owner) (Date)

Approved by: _____
 Funding or Financing Entity (if applicable) (Date)

Progress Estimate - Unit Price Work

For (Contract):												Application Number:		
24-55 Burleigh Water Tower Rehabilitation												2		
Estimate Period:												Application Date:		
08/13/2024 TO 2/3/2025												2/3/2025		
A					B	C	D	E	F	G	H	I	J	K
Item			Contract Information			Quantity Previously Billed	Estimated Quantity Billed This Period	Estimated Quantity Billed to Date	Value of Work Billed This Period	Value of Work Billed To Date	Materials Presently Stored (not in C)	Total Complet and Stored to Date	%	Balance to Finish (B - F)
Bid Item No.	Description	Item Quantity	Units	Unit Price	Total Value of Item (\$)									
A1	SPALL REPAIR, 2IN DEEP	4	SQ FT	\$500	\$2,000.00	4	0	4	\$0.00	\$2,000.00	\$0.00	\$2,000.00	100.0%	\$0.00
A2	CRACK REPAIR	150	LN FT	\$20	\$3,000.00	150	0	150	\$0.00	\$3,000.00	\$0.00	\$3,000.00	100.0%	\$0.00
A3	GROUT REPAIR	5	LN FT	\$200	\$1,000.00	5	0	5	\$0.00	\$1,000.00	\$0.00	\$1,000.00	100.0%	\$0.00
A4	SPLASH PAD	1	LS	\$5,000	\$5,000.00	0	1	1	\$5,000.00	\$5,000.00	\$0.00	\$5,000.00	100.0%	\$0.00
B1	RISER MANWAY	1	LS	\$10,000	\$10,000.00	1	0	1	\$0.00	\$10,000.00	\$0.00	\$10,000.00	100.0%	\$0.00
B2	WET INTERIOR ROOF HATCH	1	LS	\$5,000	\$5,000.00	1	0	1	\$0.00	\$5,000.00	\$0.00	\$5,000.00	100.0%	\$0.00
B3	OVERFLOW PIPE DISCHARGE MODIFICATION	1	LS	\$5,000	\$5,000.00	0	1	1	\$5,000.00	\$5,000.00	\$0.00	\$5,000.00	100.0%	\$0.00
B4	WET INTERIOR LADDER	1	LS	\$10,000	\$10,000.00	1	0	1	\$0.00	\$10,000.00	\$0.00	\$10,000.00	100.0%	\$0.00
B5	VANDAL GUARD	1	LS	\$3,000	\$3,000.00	1	0	1	\$0.00	\$3,000.00	\$0.00	\$3,000.00	100.0%	\$0.00
B6	ROOF PLATFORM	1	LS	\$15,000	\$15,000.00	1	0	1	\$0.00	\$15,000.00	\$0.00	\$15,000.00	100.0%	\$0.00
B7	SWING GATE	1	LS	\$2,000	\$2,000.00	1	0	1	\$0.00	\$2,000.00	\$0.00	\$2,000.00	100.0%	\$0.00
B8	ROOF VENT	1	LS	\$10,000	\$10,000.00	1	0	1	\$0.00	\$10,000.00	\$0.00	\$10,000.00	100.0%	\$0.00
B9	ROOF HANDRAIL AND PAINTERS RAILING	1	LS	\$15,000	\$15,000.00	1	0	1	\$0.00	\$15,000.00	\$0.00	\$15,000.00	100.0%	\$0.00
B10	SIPHON PIPE	1	LS	\$5000	\$5,000.00	1	0	1	\$0.00	\$5,000.00	\$0.00	\$5,000.00	100.0%	\$0.00
C1	EXTERIOR OVERCOAT	1	LS	\$400000	\$400,000.00	0.8	0.2	1	\$80,000.00	\$400,000.00	\$0.00	\$400,000.00	100.0%	\$0.00
C2	WET INTERIOR REPAINT	1	LS	\$450,000	\$450,000.00	1	0	1	\$0.00	\$450,000.00	\$0.00	\$450,000.00	100.0%	\$0.00
C3	SEAM SEALER	1	LS	\$10,000	\$10,000.00	1	0	1	\$0.00	\$10,000.00	\$0.00	\$10,000.00	100.0%	\$0.00
C4	PIT PIPING REPAINT	2	LS	\$5,000	\$10,000.00	1	0	1	\$0.00	\$5,000.00	\$0.00	\$5,000.00	50.0%	\$5,000.00
D1	MIXER	1	LS	\$25,000	\$25,000.00	0	1	1	\$25,000.00	\$25,000.00	\$0.00	\$25,000.00	100.0%	\$0.00
TOTAL CONTRACT					\$986,000.00				\$115,000.00	\$981,000.00	\$0.00	\$981,000.00	97.4%	\$5,000.00

WAIVER OF LIEN

Wauwatosa, Wisconsin

Date: 2/5/2025

FOR VALUE RECEIVED, the undersigned hereby waives all rights and claims for lien given by Chapter 779 of the Statutes, or otherwise, arising out of or under Contract Number 24-55 with the City of Wauwatosa for Burleigh Water Tower Rehabilitation, and the undersigned hereby acknowledges payment in full of all monies due under the above-described contract and hereby fully and finally releases and holds the City of Wauwatosa harmless from all claims, demands, causes of actions, damages, or liabilities of whatsoever kind arising from said contract.

O&J COATINGS, INC.

(Contractor)

By



(President) J ARTURO ANDRADE

Jose A.

(Secretary)

JOSE A ANDRADE

(Corporate Seal)

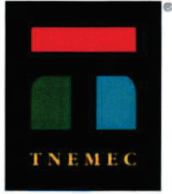

TNEMEC COMPANY, INC.

Credit Department

123 West 23rd Avenue, North Kansas City, MO 64116 USA

TEL +1 816-483-3400 FAX +1 816-326-4296 tnemec.com

UNCONDITIONAL FINAL WAIVER OF LIEN

TO ALL WHOM IT MAY CONCERN:

Whereas, the undersigned, **TNEMEC COMPANY, INC.**, has furnished material to **O&J COATINGS, INC.**

WAUWATOSA REHAB

INVOICES 6/26/2024 - 9/3/2024:

2677043 - \$58,695.45

2678301 - \$13,690.35

2679862 - \$1,336.89

2682301 - \$2,151.26

2683170 - \$19,368.06

2687454 - \$3,220.70

2675946 - \$19,368.06

2678055 - \$73,741.57

2677281 - \$22,238.19

2678422 - \$10,807.26

TOTAL - \$225,107.87

Now, therefore, the undersigned, does hereby waive and release any and all lien or claim of or right to lien, with respect to and on the above material, fixtures, apparatus, or machinery furnished, and on the monies or other consideration due or to become due from the owner.

Dated: February 6, 2025

Tnemec Company, Inc

Kelly Hamilton
Credit Analyst

The Taylor Way

SERVING INSURANCE COMPANIES
2950 S. SHAVER • SUITE A - 1 • PASADENA, TX 77502 • (713) 944-9614

INVOICE

DATE 9-4-24

JOB # 262-B

CLEANING: overspray

FROM: 10 automobiles

FOR: O & J Coatings, Inc.
arturo andrade 817-917-1040
Waukesha, Wisconsin job
10 automobiles at \$600.00 per auto = \$6,000.00

Paid

9-5-24

#

10713

\$ 6,000.00

CHECKWRITER: Please
place Job # on check to
insure proper credit.
Thank You

The Taylor Way

SERVING INSURANCE COMPANIES

2950 S. SHAVER • SUITE A - 1 • PASADENA, TX 77502 • (713) 944-9614

INVOICE

DATE 9-16-24

JOB # 262-C

CLEANING: overspray

FROM: 10 automobiles

FOR: O + J Coatings, Inc.
arturo andrade 817-917-1040
waubesa, Wisconsin job
10 automobiles at \$600.00 per auto = \$6,000.00

Paid

9-13-24

#

10761

\$ 6,000.00

CHECKWRITER: Please
place Job # on check to
insure proper credit.

Thank You

SERVING INSURANCE COMPANIES

Name Olivia Fischer Date 9-17-24
Year 2013 Make Ford Model Fusion Color Red
License # AUK 2246

Driver Side

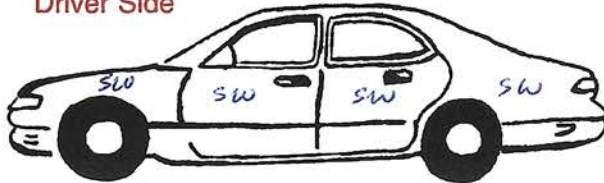

Passenger Side

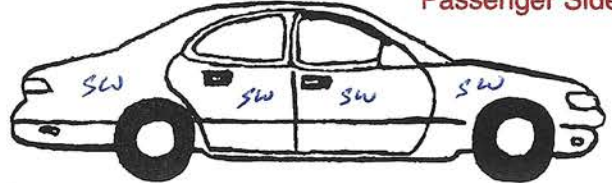

SS-Surface Scratches
SM-Swirl Marks
RC-Rock Chips
ST-Stained

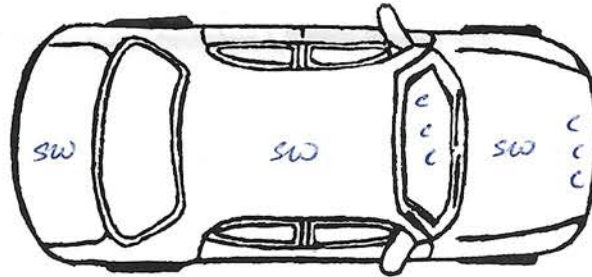

B-Burned
S-Scratched
F-Faded/Oxidized
R-Rust
C-Chips

Comments Rock chips on front hood & windshield. Spider webbing on entire vehicle.

I hereby authorize The Taylor Way to make repairs to the vehicle described above. I have been notified of pre-existing damage as stated above and hold no liability against The Taylor Way for pre-existing damages. In case of a disagreement The Taylor Way may exercise the right to use an independent adjustment firm. Should any legal action be required to enforce this contract, the court venue will be in Harris County, Texas.

OF Initials

I have chosen not to inspect my vehicle with The Taylor Way representative and; therefore, will not hold The Taylor Way responsible for scratches, rock chips, door dings, etc.

_____ Initials

RECEIPT OF SATISFACTION, RELEASE, AND AUTHORIZATION OF PAYMENT

All repairs which I authorized to my vehicle have been inspected by me and found to be repaired satisfactorily by The Taylor Way. If paid for by another party, I hereby authorize that payment be made directly to The Taylor Way, of a sum representing the repair cost, which payment fully discharges all claims I have on account of the damage to my vehicle.

If paid to me, I agree to immediately deliver the payment draft to The Taylor Way. If the draft is made payable to me, I authorize The Taylor Way to endorse my name to the payment draft and collect the same.

*Thank u! so nice & shiny
Thank You.*

Please Sign Here: *Olivia Fischer* Date: 9-17-24

Print Last Name Here: Fischer Job #: 262

SERVING INSURANCE COMPANIES

Name Kenishia Wherry Date 9-17-24
Year 2011 Make KIA Model Sorento Color Black
License # ATE 6919

Driver Side

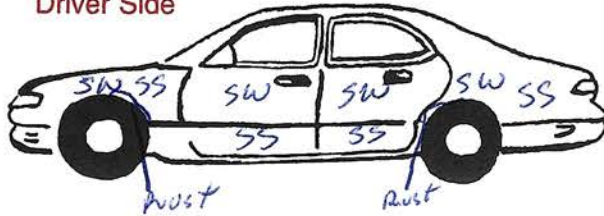

Passenger Side

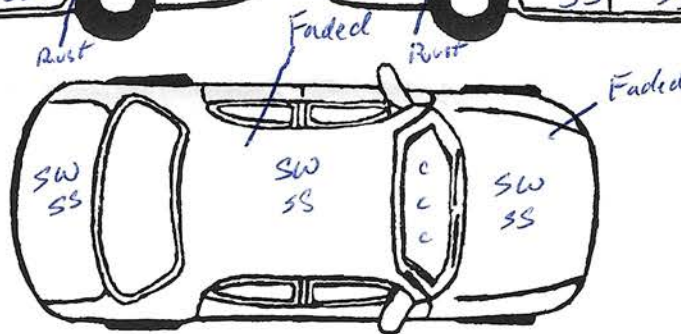
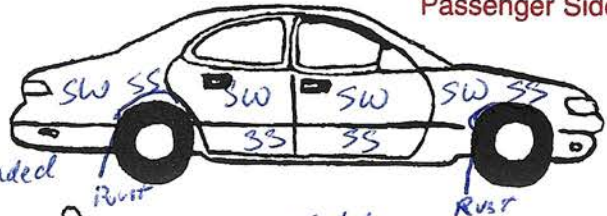

SS-Surface Scratches
SM-Swirl Marks
RC-Rock Chips
ST-Stained

B-Burned
S-Scratched
F-Faded/Oxidized
R-Rust
C-Chips

Comments Rock chips on front hood, & windshield. Spider webbing and surface scratches on entire vehicle. Top and hood Faded. Rust around wheel wells.

I hereby authorize The Taylor Way to make repairs to the vehicle described above. I have been notified of pre-existing damage as stated above and hold no liability against The Taylor Way for pre-existing damages. In case of a disagreement The Taylor Way may exercise the right to use an independent adjustment firm. Should any legal action be required to enforce this contract, the court venue will be in Harris County, Texas.

KW Initials

I have chosen not to inspect my vehicle with The Taylor Way representative and; therefore, will not hold The Taylor Way responsible for scratches, rock chips, door dings, etc.

Initials

RECEIPT OF SATISFACTION, RELEASE, AND AUTHORIZATION OF PAYMENT

All repairs which I authorized to my vehicle have been inspected by me and found to be repaired satisfactorily by The Taylor Way. If paid for by another party, I hereby authorize that payment be made directly to The Taylor Way, of a sum representing the repair cost, which payment fully discharges all claims I have on account of the damage to my vehicle.

If paid to me, I agree to immediately deliver the payment draft to The Taylor Way. If the draft is made payable to me, I authorize The Taylor Way to endorse my name to the payment draft and collect the same.

Thank You.

Please Sign Here: Kenishia Wherry

Date: 9-17-24

Print Last Name Here: Wherry

Job #: 262

SERVING INSURANCE COMPANIES

Name Hannah Gemmel Date 9-17-24
Year 2010 Make Ford Model Fusion Color Silver
License # AXE 3597

Driver Side

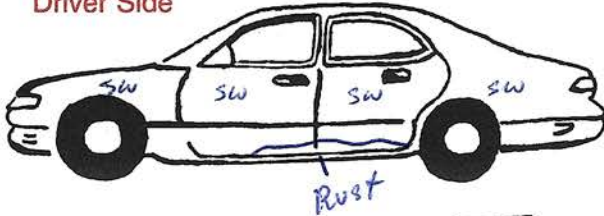

Passenger Side

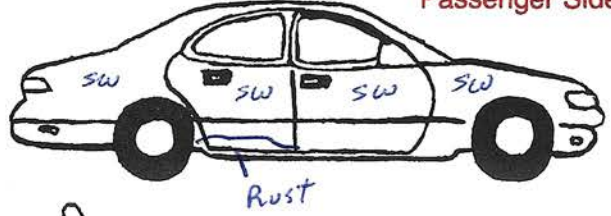

SS-Surface Scratches
SM-Swirl Marks
RC-Rock Chips
ST-Stained

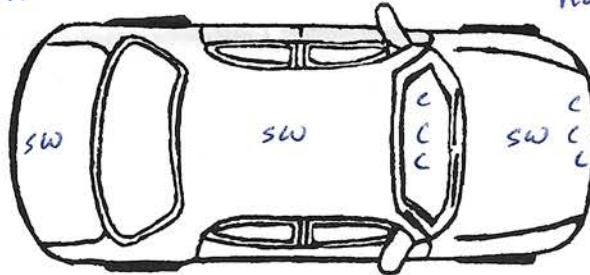

B-Burned
S-Scratched
F-Faded/Oxidized
R-Rust
C-Chips

Comments Rock chips on front, hood, & windshield. Spider webbing on entire vehicle.
Rust on bottom

I hereby authorize The Taylor Way to make repairs to the vehicle described above. I have been notified of pre-existing damage as stated above and hold no liability against The Taylor Way for pre-existing damages. In case of a disagreement The Taylor Way may exercise the right to use an independent adjustment firm. Should any legal action be required to enforce this contract, the court venue will be in Harris County, Texas.

ng Initials

I have chosen not to inspect my vehicle with The Taylor Way representative and; therefore, will not hold The Taylor Way responsible for scratches, rock chips, door dings, etc.

Initials

RECEIPT OF SATISFACTION, RELEASE, AND AUTHORIZATION OF PAYMENT

All repairs which I authorized to my vehicle have been inspected by me and found to be repaired satisfactorily by The Taylor Way. If paid for by another party, I hereby authorize that payment be made directly to The Taylor Way, of a sum representing the repair cost, which payment fully discharges all claims I have on account of the damage to my vehicle.

If paid to me, I agree to immediately deliver the payment draft to The Taylor Way. If the draft is made payable to me, I authorize The Taylor Way to endorse my name to the payment draft and collect the same.

Thank You.

Please Sign Here:

[Signature]

Date:

9-17-24

Print Last Name Here:

Gemmel

Job #:

262

SERVING INSURANCE COMPANIES

Name Estefania Isasi Date 9-18-24
Year 2018 Make BMW Model X1 Color Blue
License # AWH 6377

Driver Side

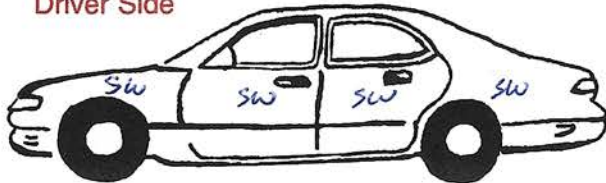

Passenger Side

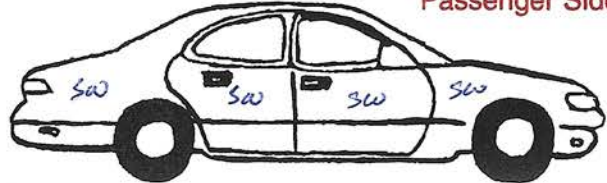

SS-Surface Scratches
SM-Swirl Marks
RC-Rock Chips
ST-Stained

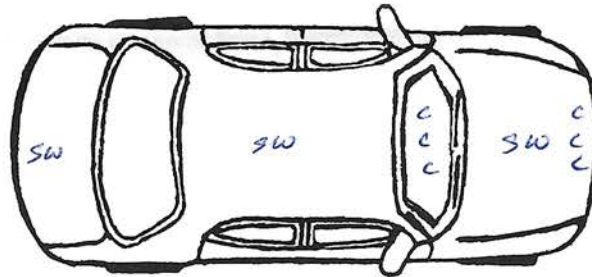

B-Burned
S-Scratched
F-Faded/Oxidized
R-Rust
C-Chips

Comments Rock chips on front hood & windshield. Spider webbing on entire vehicle

I hereby authorize The Taylor Way to make repairs to the vehicle described above. I have been notified of pre-existing damage as stated above and hold no liability against The Taylor Way for pre-existing damages. In case of a disagreement The Taylor Way may exercise the right to use an independent adjustment firm. Should any legal action be required to enforce this contract, the court venue will be in Harris County, Texas.

E-I Initials

I have chosen not to inspect my vehicle with The Taylor Way representative and; therefore, will not hold The Taylor Way responsible for scratches, rock chips, door dings, etc.

Initials

RECEIPT OF SATISFACTION, RELEASE, AND AUTHORIZATION OF PAYMENT

All repairs which I authorized to my vehicle have been inspected by me and found to be repaired satisfactorily by The Taylor Way. If paid for by another party, I hereby authorize that payment be made directly to The Taylor Way, of a sum representing the repair cost, which payment fully discharges all claims I have on account of the damage to my vehicle.

If paid to me, I agree to immediately deliver the payment draft to The Taylor Way. If the draft is made payable to me, I authorize The Taylor Way to endorse my name to the payment draft and collect the same.

Thank You.

Please Sign Here: Estefania Isasi Date: 9-18-24

Print Last Name Here: Isasi Job #: 262

SERVING INSURANCE COMPANIES

Name Chris Hahn Date 9-18-24
Year 2020 Make Toyota Model Rav 4 Color Blue
License # AUN 6435

Driver Side

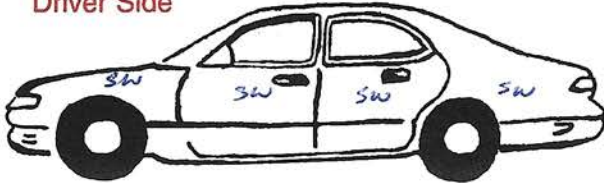

Passenger Side

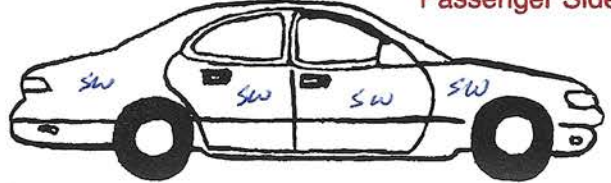

SS-Surface Scratches
SM-Swirl Marks
RC-Rock Chips
ST-Stained

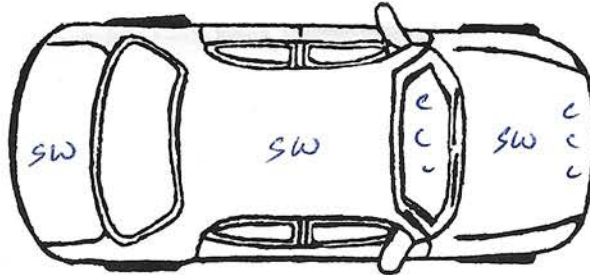

B-Burned
S-Scratched
F-Faded/Oxidized
R-Rust
C-Chips

Comments Rock chips on front, hood, & windshield. Spider webbing on entire vehicle.

I hereby authorize The Taylor Way to make repairs to the vehicle described above. I have been notified of pre-existing damage as stated above and hold no liability against The Taylor Way for pre-existing damages. In case of a disagreement The Taylor Way may exercise the right to use an independent adjustment firm. Should any legal action be required to enforce this contract, the court venue will be in Harris County, Texas.

[Signature] Initials

I have chosen not to inspect my vehicle with The Taylor Way representative and; therefore, will not hold The Taylor Way responsible for scratches, rock chips, door dings, etc.

_____ Initials

RECEIPT OF SATISFACTION, RELEASE, AND AUTHORIZATION OF PAYMENT

All repairs which I authorized to my vehicle have been inspected by me and found to be repaired satisfactorily by The Taylor Way. If paid for by another party, I hereby authorize that payment be made directly to The Taylor Way, of a sum representing the repair cost, which payment fully discharges all claims I have on account of the damage to my vehicle.

If paid to me, I agree to immediately deliver the payment draft to The Taylor Way. If the draft is made payable to me, I authorize The Taylor Way to endorse my name to the payment draft and collect the same.

Thank You.

Please Sign Here: [Signature] Date: 9-18-24

Print Last Name Here: Hahn Job #: 262

SERVING INSURANCE COMPANIES

Name Ari Hahn Date 9-19-24
Year 2012 Make Mitsubishi Model Outlander Color Red
License # ALW 4669

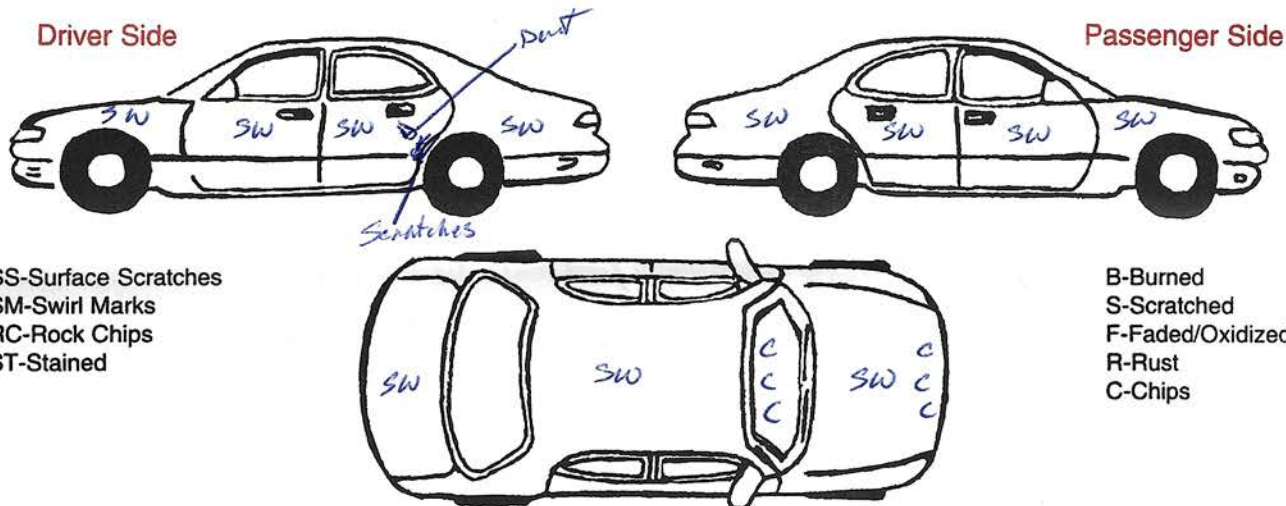

Comments Rock chips on front hood, & windshield. Spider webbing on entire vehicle.
Dent and scratches on driver side rear door.

I hereby authorize **The Taylor Way** to make repairs to the vehicle described above. I have been notified of pre-existing damage as stated above and hold no liability against **The Taylor Way** for pre-existing damages. In case of a disagreement **The Taylor Way** may exercise the right to use an independent adjustment firm. Should any legal action be required to enforce this contract, the court venue will be in Harris County, Texas.

Mk Initials

I have chosen not to inspect my vehicle with **The Taylor Way** representative and; therefore, will not hold **The Taylor Way** responsible for scratches, rock chips, door dings, etc.

Initials

RECEIPT OF SATISFACTION, RELEASE, AND AUTHORIZATION OF PAYMENT

All repairs which I authorized to my vehicle have been inspected by me and found to be repaired satisfactorily by The Taylor Way. If paid for by another party, I hereby authorize that payment be made directly to The Taylor Way, of a sum representing the repair cost, which payment fully discharges all claims I have on account of the damage to my vehicle.

If paid to me, I agree to immediately deliver the payment draft to The Taylor Way. If the draft is made payable to me, I authorize The Taylor Way to endorse my name to the payment draft and collect the same.

Please Sign Here: Ari Hahn *good job!* Date: 9-19-24 Thank You.

Print Last Name Here: Hahn Job #: 262

SERVING INSURANCE COMPANIES

Name Brianna Hickman Date 9-19-24
Year 2008 Make Nissan Model Altima Color Tan
License # AJG 6685

Driver Side

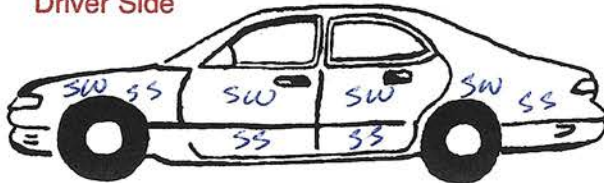

Passenger Side

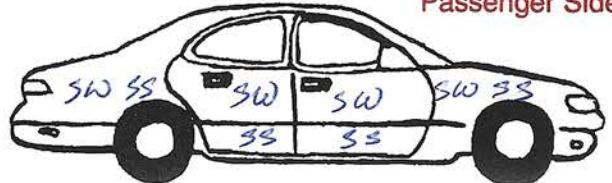

SS-Surface Scratches
SM-Swirl Marks
RC-Rock Chips
ST-Stained

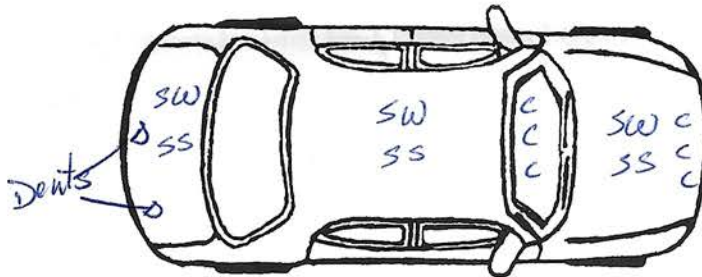

B-Burned
S-Scratched
F-Faded/Oxidized
R-Rust
C-Chips

Comments Rock chips on front, hood, & windshield. Spider webbing and Surface scratches on entire vehicle. Dents on trunk.

I hereby authorize The Taylor Way to make repairs to the vehicle described above. I have been notified of pre-existing damage as stated above and hold no liability against The Taylor Way for pre-existing damages. In case of a disagreement The Taylor Way may exercise the right to use an independent adjustment firm. Should any legal action be required to enforce this contract, the court venue will be in Harris County, Texas.

B.H Initials

I have chosen not to inspect my vehicle with The Taylor Way representative and; therefore, will not hold The Taylor Way responsible for scratches, rock chips, door dings, etc.

Initials

RECEIPT OF SATISFACTION, RELEASE, AND AUTHORIZATION OF PAYMENT

All repairs which I authorized to my vehicle have been inspected by me and found to be repaired satisfactorily by The Taylor Way. If paid for by another party, I hereby authorize that payment be made directly to The Taylor Way, of a sum representing the repair cost, which payment fully discharges all claims I have on account of the damage to my vehicle.

If paid to me, I agree to immediately deliver the payment draft to The Taylor Way. If the draft is made payable to me, I authorize The Taylor Way to endorse my name to the payment draft and collect the same.

great job! car was spotless!
Thank You.

Please Sign Here: [Signature]

Date: 9-19-24

Print Last Name Here: Hickman

Job #: 262

SERVING INSURANCE COMPANIES

Name James Brooks Date 9-19-24
Year 2017 Make Honda Model Civic Color Gray
License # AXT 3215

Driver Side

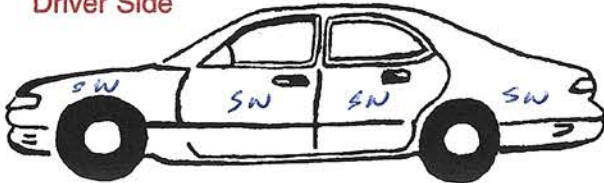

Passenger Side

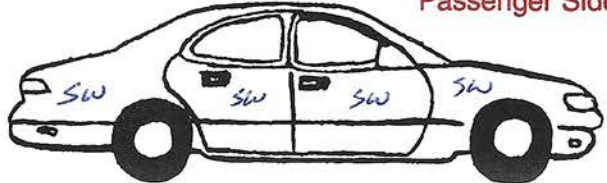

SS-Surface Scratches
SM-Swirl Marks
RC-Rock Chips
ST-Stained

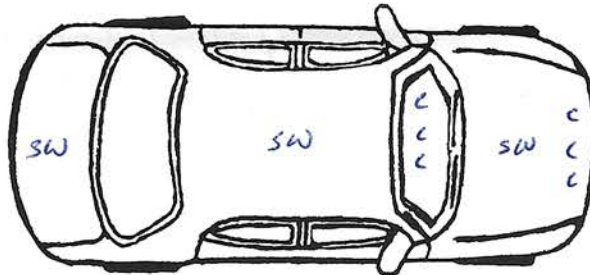

B-Burned
S-Scratched
F-Faded/Oxidized
R-Rust
C-Chips

Comments Rock chips on front hood, & windshield. Spider webbing on entire vehicle.

I hereby authorize The Taylor Way to make repairs to the vehicle described above. I have been notified of pre-existing damage as stated above and hold no liability against The Taylor Way for pre-existing damages. In case of a disagreement The Taylor Way may exercise the right to use an independent adjustment firm. Should any legal action be required to enforce this contract, the court venue will be in Harris County, Texas.

JTB Initials

I have chosen not to inspect my vehicle with The Taylor Way representative and; therefore, will not hold The Taylor Way responsible for scratches, rock chips, door dings, etc.

_____ Initials

RECEIPT OF SATISFACTION, RELEASE, AND AUTHORIZATION OF PAYMENT

All repairs which I authorized to my vehicle have been inspected by me and found to be repaired satisfactorily by The Taylor Way. If paid for by another party, I hereby authorize that payment be made directly to The Taylor Way, of a sum representing the repair cost, which payment fully discharges all claims I have on account of the damage to my vehicle.

If paid to me, I agree to immediately deliver the payment draft to The Taylor Way. If the draft is made payable to me, I authorize The Taylor Way to endorse my name to the payment draft and collect the same.

Thanks! great job!

Thank You.

Please Sign Here: [Signature] Date: 9-19-24

Print Last Name Here: Brooks Job #: 262

SERVING INSURANCE COMPANIES

Name Therese Schirger Date 9-20-24
Year 2011 Make VW Model Setta Color Black
License # 419 XGS

Driver Side

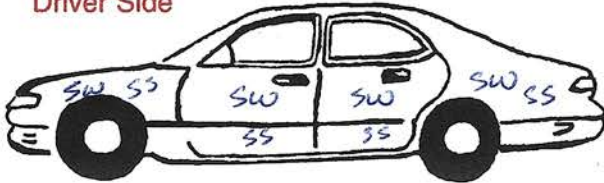

Passenger Side

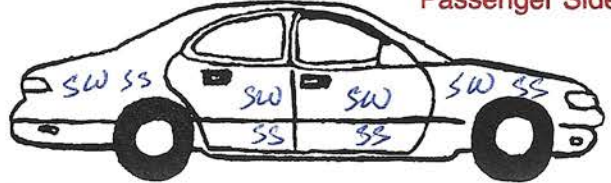

SS-Surface Scratches
SM-Swirl Marks
RC-Rock Chips
ST-Stained

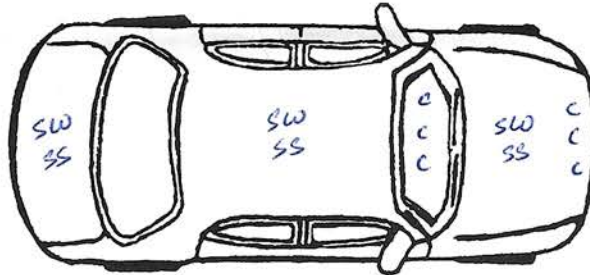

B-Burned
S-Scratched
F-Faded/Oxidized
R-Rust
C-Chips

Comments Rock chips on front, hood, & windshield. Spider webbing and surface scratches on entire vehicle.

I hereby authorize The Taylor Way to make repairs to the vehicle described above. I have been notified of pre-existing damage as stated above and hold no liability against The Taylor Way for pre-existing damages. In case of a disagreement The Taylor Way may exercise the right to use an independent adjustment firm. Should any legal action be required to enforce this contract, the court venue will be in Harris County, Texas.

TMS Initials

I have chosen not to inspect my vehicle with The Taylor Way representative and; therefore, will not hold The Taylor Way responsible for scratches, rock chips, door dings, etc.

Initials

RECEIPT OF SATISFACTION, RELEASE, AND AUTHORIZATION OF PAYMENT

All repairs which I authorized to my vehicle have been inspected by me and found to be repaired satisfactorily by The Taylor Way. If paid for by another party, I hereby authorize that payment be made directly to The Taylor Way, of a sum representing the repair cost, which payment fully discharges all claims I have on account of the damage to my vehicle.

If paid to me, I agree to immediately deliver the payment draft to The Taylor Way. If the draft is made payable to me, I authorize The Taylor Way to endorse my name to the payment draft and collect the same.

Thank You.

Please Sign Here: Therese Schirger Date: 9-20-24

Print Last Name Here: Schirger Job #: 262

SERVING INSURANCE COMPANIES

Name Athony Williams Date 9-20-24
Year 2017 Make Infiniti Model QX60 Color Black
License # ALE 2990

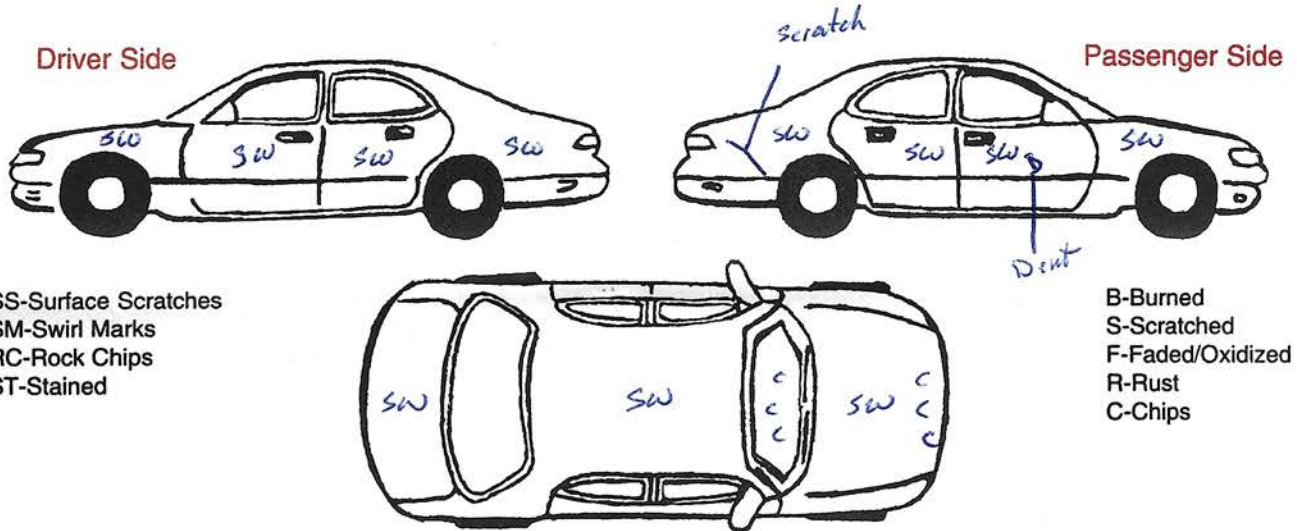

SS-Surface Scratches
SM-Swirl Marks
RC-Rock Chips
ST-Stained

B-Burned
S-Scratched
F-Faded/Oxidized
R-Rust
C-Chips

Comments Rock chips on front hood & windshield - Spider webbing on entire vehicle.
Scratch passenger side rear fender. Dent passenger side Front door.

I hereby authorize **The Taylor Way** to make repairs to the vehicle described above. I have been notified of pre-existing damage as stated above and hold no liability against **The Taylor Way** for pre-existing damages. In case of a disagreement **The Taylor Way** may exercise the right to use an independent adjustment firm. Should any legal action be required to enforce this contract, the court venue will be in Harris County, Texas.

_____ Initials

I have chosen not to inspect my vehicle with **The Taylor Way** representative and; therefore, will not hold **The Taylor Way** responsible for scratches, rock chips, door dings, etc.

_____ Initials

RECEIPT OF SATISFACTION, RELEASE, AND AUTHORIZATION OF PAYMENT

All repairs which I authorized to my vehicle have been inspected by me and found to be repaired satisfactorily by The Taylor Way. If paid for by another party, I hereby authorize that payment be made directly to The Taylor Way, of a sum representing the repair cost, which payment fully discharges all claims I have on account of the damage to my vehicle.

If paid to me, I agree to immediately deliver the payment draft to The Taylor Way. If the draft is made payable to me, I authorize The Taylor Way to endorse my name to the payment draft and collect the same.

Thank You.

Please Sign Here: *Athony Williams* Date: 9-20-24

Print Last Name Here: Williams Job #: 262

SERVING INSURANCE COMPANIES

Name Stephanie Bucio Date 9-13-24
Year 2022 Make Ford Model Bronco Color Blue
License # ANY 7772

Driver Side

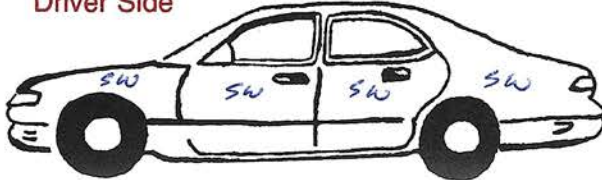

Passenger Side

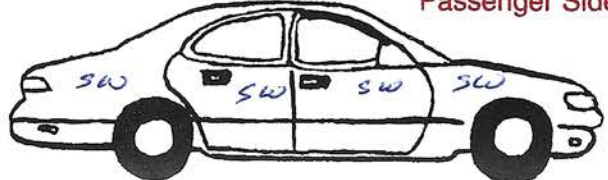

SS-Surface Scratches
SM-Swirl Marks
RC-Rock Chips
ST-Stained

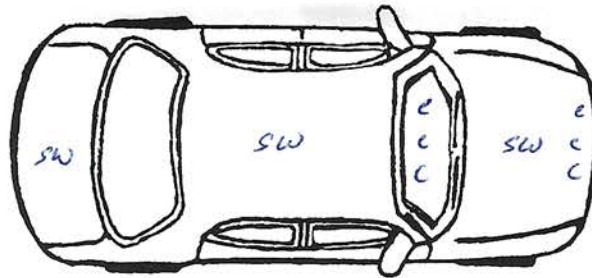

B-Burned
S-Scratched
F-Faded/Oxidized
R-Rust
C-Chips

Comments Rock chips on front, hood, & windshield. Spider webbing on entire vehicle.

I hereby authorize **The Taylor Way** to make repairs to the vehicle described above. I have been notified of pre-existing damage as stated above and hold no liability against **The Taylor Way** for pre-existing damages. In case of a disagreement **The Taylor Way** may exercise the right to use an independent adjustment firm. Should any legal action be required to enforce this contract, the court venue will be in Harris County, Texas.

[Signature] Initials

I have chosen not to inspect my vehicle with **The Taylor Way** representative and; therefore, will not hold **The Taylor Way** responsible for scratches, rock chips, door dings, etc.

_____ Initials

RECEIPT OF SATISFACTION, RELEASE, AND AUTHORIZATION OF PAYMENT

All repairs which I authorized to my vehicle have been inspected by me and found to be repaired satisfactorily by The Taylor Way. If paid for by another party, I hereby authorize that payment be made directly to The Taylor Way, of a sum representing the repair cost, which payment fully discharges all claims I have on account of the damage to my vehicle.

If paid to me, I agree to immediately deliver the payment draft to The Taylor Way. If the draft is made payable to me, I authorize The Taylor Way to endorse my name to the payment draft and collect the same.

Nice

Thank You.

Please Sign Here: [Signature] Date: 9-13-24

Print Last Name Here: Bucio Job #: 262

SERVING INSURANCE COMPANIES

Name Kelly Campbell Date 9-13-24
Year 2016 Make Dodge Model Charger Color White
License # AJE 5991

Driver Side

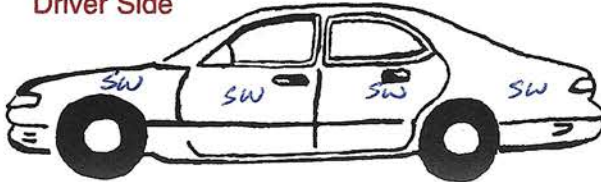

Passenger Side

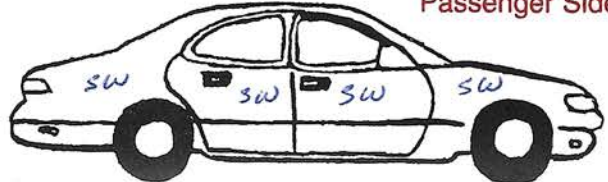

SS-Surface Scratches
SM-Swirl Marks
RC-Rock Chips
ST-Stained

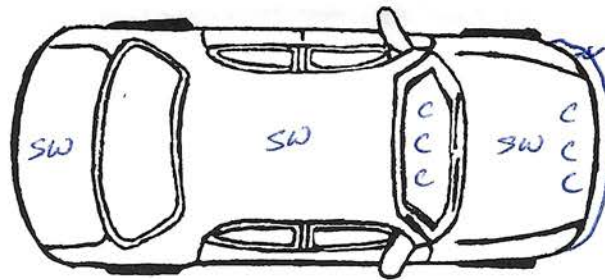

Paint
Cracking

B-Burned
S-Scratched
F-Faded/Oxidized
R-Rust
C-Chips

Comments Rock chips on front, hood, & windshield. Spider webbing on entire vehicle.
Paint cracking on front bumper.

I hereby authorize The Taylor Way to make repairs to the vehicle described above. I have been notified of pre-existing damage as stated above and hold no liability against The Taylor Way for pre-existing damages. In case of a disagreement The Taylor Way may exercise the right to use an independent adjustment firm. Should any legal action be required to enforce this contract, the court venue will be in Harris County, Texas.

_____ Initials

I have chosen not to inspect my vehicle with The Taylor Way representative and; therefore, will not hold The Taylor Way responsible for scratches, rock chips, door dings, etc.

KC Initials

RECEIPT OF SATISFACTION, RELEASE, AND AUTHORIZATION OF PAYMENT

All repairs which I authorized to my vehicle have been inspected by me and found to be repaired satisfactorily by The Taylor Way. If paid for by another party, I hereby authorize that payment be made directly to The Taylor Way, of a sum representing the repair cost, which payment fully discharges all claims I have on account of the damage to my vehicle.

If paid to me, I agree to immediately deliver the payment draft to The Taylor Way. If the draft is made payable to me, I authorize The Taylor Way to endorse my name to the payment draft and collect the same.

Thank You.

Please Sign Here K. Campbell

Date: 9-13-24

Print Last Name Here: Campbell

Job #: 262

SERVING INSURANCE COMPANIES

Name John Brown Date 9-14-24
Year 2022 Make Nissan Truck Model P.U. Color Black
License # 2750182

Driver Side

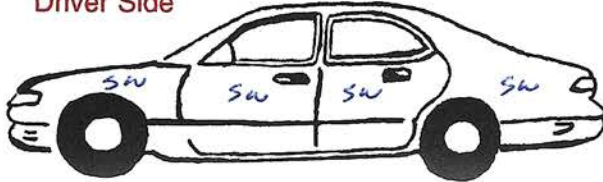

Passenger Side

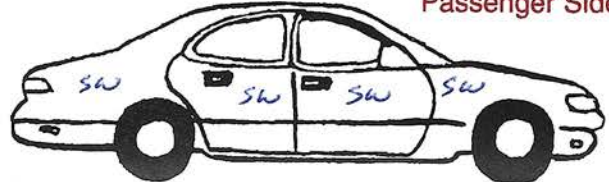

SS-Surface Scratches
SM-Swirl Marks
RC-Rock Chips
ST-Stained

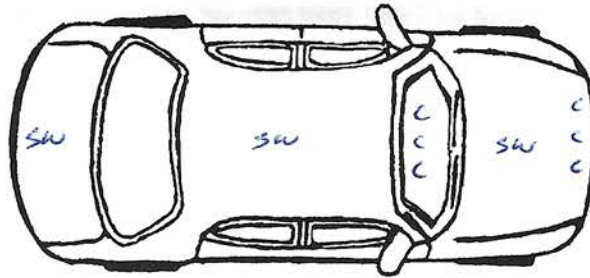

B-Burned
S-Scatched
F-Faded/Oxidized
R-Rust
C-Chips

Comments Rock chips on front hood, & windshield Spider webbing on entire vehicle.

I hereby authorize **The Taylor Way** to make repairs to the vehicle described above. I have been notified of pre-existing damage as stated above and hold no liability against **The Taylor Way** for pre-existing damages. In case of a disagreement **The Taylor Way** may exercise the right to use an independent adjustment firm. Should any legal action be required to enforce this contract, the court venue will be in Harris County, Texas.

JB Initials

I have chosen not to inspect my vehicle with **The Taylor Way** representative and; therefore, will not hold **The Taylor Way** responsible for scratches, rock chips, door dings, etc.

Initials

RECEIPT OF SATISFACTION, RELEASE, AND AUTHORIZATION OF PAYMENT

All repairs which I authorized to my vehicle have been inspected by me and found to be repaired satisfactorily by The Taylor Way. If paid for by another party, I hereby authorize that payment be made directly to The Taylor Way, of a sum representing the repair cost, which payment fully discharges all claims I have on account of the damage to my vehicle.

If paid to me, I agree to immediately deliver the payment draft to The Taylor Way. If the draft is made payable to me, I authorize The Taylor Way to endorse my name to the payment draft and collect the same.

Thank You.

Please Sign Here: [Signature] Date: 9-14-24

Print Last Name Here: Brown Job #: 262

SERVING INSURANCE COMPANIES

Name Jamie Read Date 9-14-24
Year 2015 Make Hyundai Model Santa Fe Color Red
License # AGL 7673

Driver Side

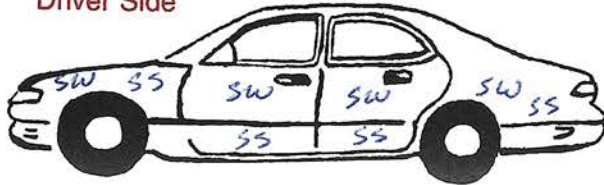

Passenger Side

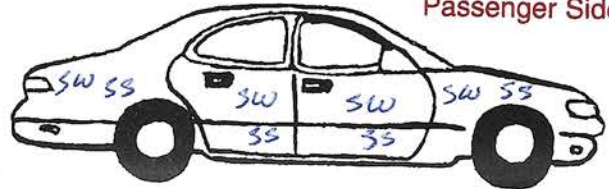

SS-Surface Scratches
SM-Swirl Marks
RC-Rock Chips
ST-Stained

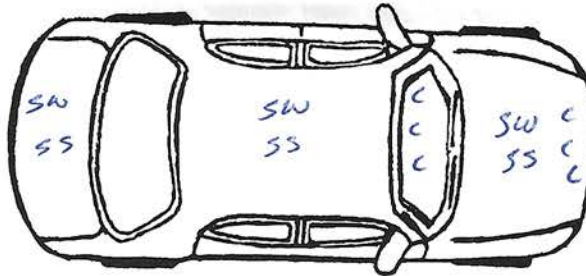

B-Burned
S-Scratched
F-Faded/Oxidized
R-Rust
C-Chips

Comments Rock chips on front, hood, & windshield. Spider webbing and surface scratches on entire vehicle.

I hereby authorize The Taylor Way to make repairs to the vehicle described above. I have been notified of pre-existing damage as stated above and hold no liability against The Taylor Way for pre-existing damages. In case of a disagreement The Taylor Way may exercise the right to use an independent adjustment firm. Should any legal action be required to enforce this contract, the court venue will be in Harris County, Texas.

_____ Initials

I have chosen not to inspect my vehicle with The Taylor Way representative and; therefore, will not hold The Taylor Way responsible for scratches, rock chips, door dings, etc.

_____ Initials

RECEIPT OF SATISFACTION, RELEASE, AND AUTHORIZATION OF PAYMENT

All repairs which I authorized to my vehicle have been inspected by me and found to be repaired satisfactorily by The Taylor Way. If paid for by another party, I hereby authorize that payment be made directly to The Taylor Way, of a sum representing the repair cost, which payment fully discharges all claims I have on account of the damage to my vehicle.

If paid to me, I agree to immediately deliver the payment draft to The Taylor Way. If the draft is made payable to me, I authorize The Taylor Way to endorse my name to the payment draft and collect the same.

great job

Thank You.

Please Sign Here: Jamie Read Date: 9-14-24

Print Last Name Here: Read Job #: 262

SERVING INSURANCE COMPANIES

Name Sara Ervin Date 9-15-24
Year 2022 Make Honda Model HRV Color Blue
License # APG 8935

Driver Side

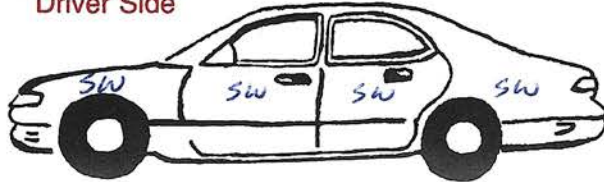

Scratches

Passenger Side

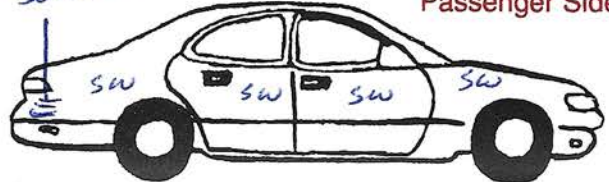

SS-Surface Scratches
SM-Swirl Marks
RC-Rock Chips
ST-Stained

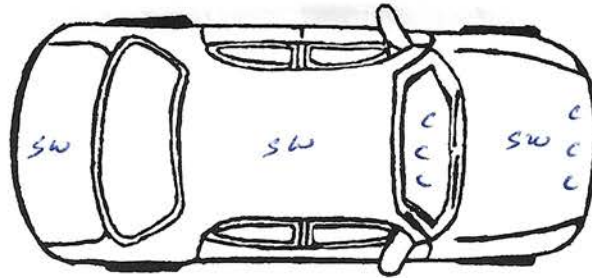

B-Burned
S-Scratched
F-Faded/Oxidized
R-Rust
C-Chips

Comments Rock chips on front hood, + windshield. Spider webbing on entire vehicle.
Scratches passenger side rear fender

I hereby authorize **The Taylor Way** to make repairs to the vehicle described above. I have been notified of pre-existing damage as stated above and hold no liability against **The Taylor Way** for pre-existing damages. In case of a disagreement **The Taylor Way** may exercise the right to use an independent adjustment firm. Should any legal action be required to enforce this contract, the court venue will be in Harris County, Texas.

_____ Initials

I have chosen not to inspect my vehicle with **The Taylor Way** representative and; therefore, will not hold **The Taylor Way** responsible for scratches, rock chips, door dings, etc.

_____ Initials

RECEIPT OF SATISFACTION, RELEASE, AND AUTHORIZATION OF PAYMENT

All repairs which I authorized to my vehicle have been inspected by me and found to be repaired satisfactorily by The Taylor Way. If paid for by another party, I hereby authorize that payment be made directly to The Taylor Way, of a sum representing the repair cost, which payment fully discharges all claims I have on account of the damage to my vehicle.

If paid to me, I agree to immediately deliver the payment draft to The Taylor Way. If the draft is made payable to me, I authorize The Taylor Way to endorse my name to the payment draft and collect the same.

Thank You.

Please Sign Here: Sara Ervin ☺ Date: 9-15-24

Print Last Name Here: Ervin Job #: 262

SERVING INSURANCE COMPANIES

Name Alex Hernandez Date 9-15-24
Year 2017 Make Chevy Model Cruze Color Gray
License # AWL 9291

Driver Side

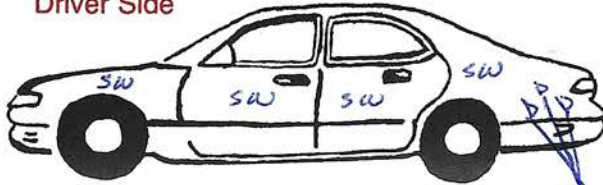

Passenger Side

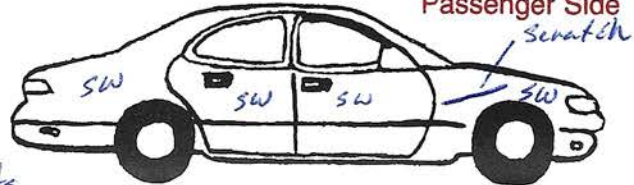

SS-Surface Scratches
SM-Swirl Marks
RC-Rock Chips
ST-Stained

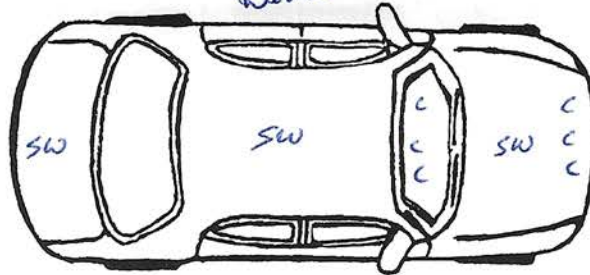

B-Burned
S-Scratched
F-Faded/Oxidized
R-Rust
C-Chips

Comments Rock chips on front hood & windshield. Spider webbing on entire vehicle.
Dents driver side rear fender - Scratch passenger side front fender.

I hereby authorize The Taylor Way to make repairs to the vehicle described above. I have been notified of pre-existing damage as stated above and hold no liability against The Taylor Way for pre-existing damages. In case of a disagreement The Taylor Way may exercise the right to use an independent adjustment firm. Should any legal action be required to enforce this contract, the court venue will be in Harris County, Texas.

_____ Initials

I have chosen not to inspect my vehicle with The Taylor Way representative and; therefore, will not hold The Taylor Way responsible for scratches, rock chips, door dings, etc.

_____ Initials

RECEIPT OF SATISFACTION, RELEASE, AND AUTHORIZATION OF PAYMENT

All repairs which I authorized to my vehicle have been inspected by me and found to be repaired satisfactorily by The Taylor Way. If paid for by another party, I hereby authorize that payment be made directly to The Taylor Way, of a sum representing the repair cost, which payment fully discharges all claims I have on account of the damage to my vehicle.

If paid to me, I agree to immediately deliver the payment draft to The Taylor Way. If the draft is made payable to me, I authorize The Taylor Way to endorse my name to the payment draft and collect the same.

Thank You.

Please Sign Here: Alex Hernandez Date: 9-15-24

Print Last Name Here: Hernandez Job #: 262

SERVING INSURANCE COMPANIES

Name Maggie Taylor Date 9-16-24
Year 2020 Make Infiniti Model QX60 Color White
License # MS AHD

Driver Side

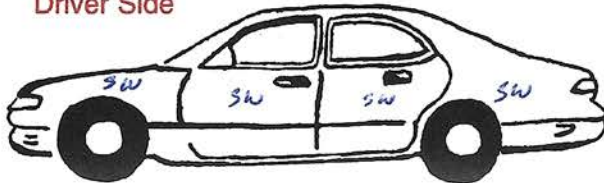

Passenger Side

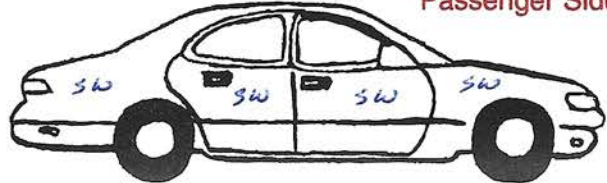

SS-Surface Scratches
SM-Swirl Marks
RC-Rock Chips
ST-Stained

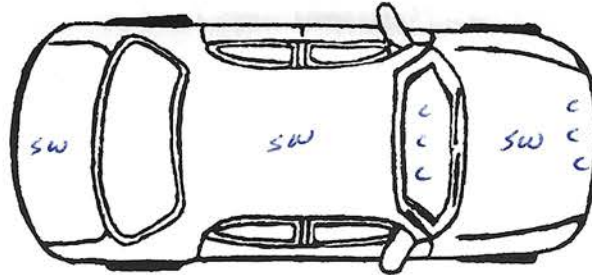

B-Burned
S-Scratched
F-Faded/Oxidized
R-Rust
C-Chips

Comments Rock chips on front hood, windshield. Spider webbing on entire vehicle.

I hereby authorize **The Taylor Way** to make repairs to the vehicle described above. I have been notified of pre-existing damage as stated above and hold no liability against **The Taylor Way** for pre-existing damages. In case of a disagreement **The Taylor Way** may exercise the right to use an independent adjustment firm. Should any legal action be required to enforce this contract, the court venue will be in Harris County, Texas.

X [Signature] Initials

I have chosen not to inspect my vehicle with **The Taylor Way** representative and; therefore, will not hold **The Taylor Way** responsible for scratches, rock chips, door dings, etc.

_____ Initials

RECEIPT OF SATISFACTION, RELEASE, AND AUTHORIZATION OF PAYMENT

All repairs which I authorized to my vehicle have been inspected by me and found to be repaired satisfactorily by The Taylor Way. If paid for by another party, I hereby authorize that payment be made directly to The Taylor Way, of a sum representing the repair cost, which payment fully discharges all claims I have on account of the damage to my vehicle.

If paid to me, I agree to immediately deliver the payment draft to The Taylor Way. If the draft is made payable to me, I authorize The Taylor Way to endorse my name to the payment draft and collect the same.

Thank You.

Please Sign Here: X [Signature] Date: 9-16-24

Print Last Name Here: Taylor Job #: 262

SERVING INSURANCE COMPANIES

Name Charlene Gonzalez Date 9-16-24
Year 2016 Make Toyota Model Avalon Color Silver
License # ANV 7175

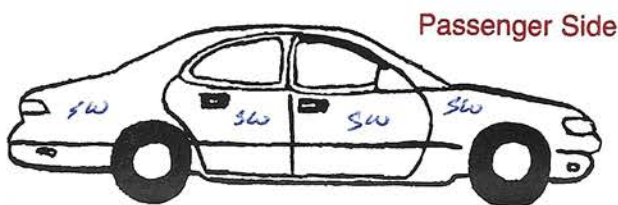
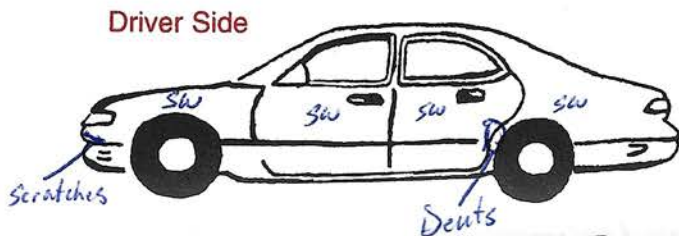

SS-Surface Scratches
SM-Swirl Marks
RC-Rock Chips
ST-Stained

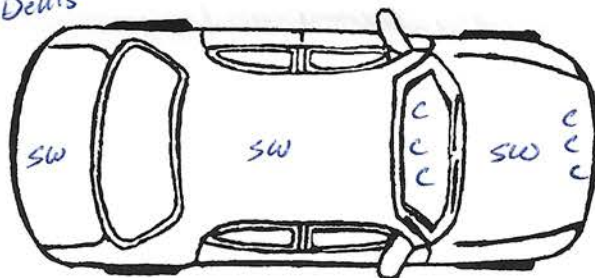

B-Burned
S-Scratched
F-Faded/Oxidized
R-Rust
C-Chips

Comments Rock chips on front, hood, & windshield. Spider webbing on entire vehicle.
Scratches on front bumper. Dents driver side rear door & fender.

I hereby authorize The Taylor Way to make repairs to the vehicle described above. I have been notified of pre-existing damage as stated above and hold no liability against The Taylor Way for pre-existing damages. In case of a disagreement The Taylor Way may exercise the right to use an independent adjustment firm. Should any legal action be required to enforce this contract, the court venue will be in Harris County, Texas.

CG Initials

I have chosen not to inspect my vehicle with The Taylor Way representative and; therefore, will not hold The Taylor Way responsible for scratches, rock chips, door dings, etc.

_____ Initials

RECEIPT OF SATISFACTION, RELEASE, AND AUTHORIZATION OF PAYMENT

All repairs which I authorized to my vehicle have been inspected by me and found to be repaired satisfactorily by The Taylor Way. If paid for by another party, I hereby authorize that payment be made directly to The Taylor Way, of a sum representing the repair cost, which payment fully discharges all claims I have on account of the damage to my vehicle.

If paid to me, I agree to immediately deliver the payment draft to The Taylor Way. If the draft is made payable to me, I authorize The Taylor Way to endorse my name to the payment draft and collect the same.

Thank You.

Please Sign Here: Charlene Gonzalez Date: 9-16-24

Print Last Name Here: Gonzalez Job #: 262

SERVING INSURANCE COMPANIES

Name Brian Stolorski Date 9-16-24
Year 2011 Make Honda Model Accord Color Blue
License # 893 UBT

Driver Side

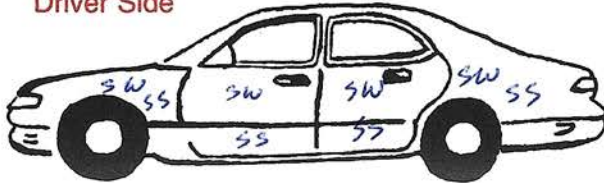

Passenger Side

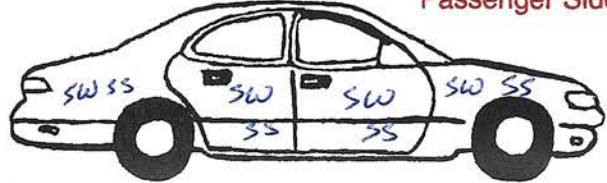

SS-Surface Scratches
SM-Swirl Marks
RC-Rock Chips
ST-Stained

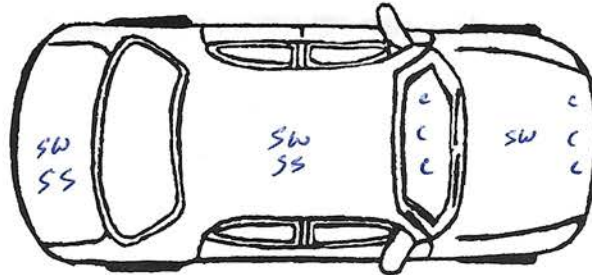

B-Burned
S-Scratched
F-Faded/Oxidized
R-Rust
C-Chips

Comments Rock chips on front hood, & windshield. Spider webbing and Surface scratches on entire vehicle

I hereby authorize The Taylor Way to make repairs to the vehicle described above. I have been notified of pre-existing damage as stated above and hold no liability against The Taylor Way for pre-existing damages. In case of a disagreement The Taylor Way may exercise the right to use an independent adjustment firm. Should any legal action be required to enforce this contract, the court venue will be in Harris County, Texas.

BS Initials

I have chosen not to inspect my vehicle with The Taylor Way representative and; therefore, will not hold The Taylor Way responsible for scratches, rock chips, door dings, etc.

_____ Initials

RECEIPT OF SATISFACTION, RELEASE, AND AUTHORIZATION OF PAYMENT

All repairs which I authorized to my vehicle have been inspected by me and found to be repaired satisfactorily by The Taylor Way. If paid for by another party, I hereby authorize that payment be made directly to The Taylor Way, of a sum representing the repair cost, which payment fully discharges all claims I have on account of the damage to my vehicle.

If paid to me, I agree to immediately deliver the payment draft to The Taylor Way. If the draft is made payable to me, I authorize The Taylor Way to endorse my name to the payment draft and collect the same.

Thank You.

Please Sign Here: [Signature]

Date: 9-16-24

Print Last Name Here: Stolorski

Job #: 262