

PERGOLA INSTALLATION GUIDE



When only the *best* will do.



Scan this QR
code to see
the installation
video series!

Heartland
Pergolas

TOOLS NEEDED

INSTALLATION

TOOLS FOR ASSEMBLY

- Drill(s)
- Miter or Circular Saw with carbide blade (*cut slowly*)
- 5/8" Drill Bit
- 5/16" Magnetic Driver(s)
- 3/8" Magnetic Driver(s)
- 6" Drill Extension(s)
- 12" Drill Extension (*2x8 option only*)
- Phillips bit for Drill
- Level
- Hammer
- Tape Measure
- String Line
- Hammer Drill if necessary for concrete or footing mounts
- Wrench for Anchors on post
- Composite shims
- Sawhorses
- Quick Clamp(s)
- Step Drill Bit (*Vari -Bit®*) – For reaming holes in aluminum
- PVC Pipe de-burring tool (*optional*)

TOOLS FOR DIGGING AND SETTING PIER TYPE FOOTINGS

- Hand diggers/Auger
- Scrap Lumber (*for making forms*)
- Concrete stakes (*for holding forms*)
- Wheel barrow or small concrete mixer
- Shovel
- Trowel

NOTE:

All fasteners for beams, rafters, purlin holders and purlins are included in kit.

Fasteners NOT provided in kit:
Post mount attachment, Ledger plate attachment, Column base to surface fasteners

COMPONENTS

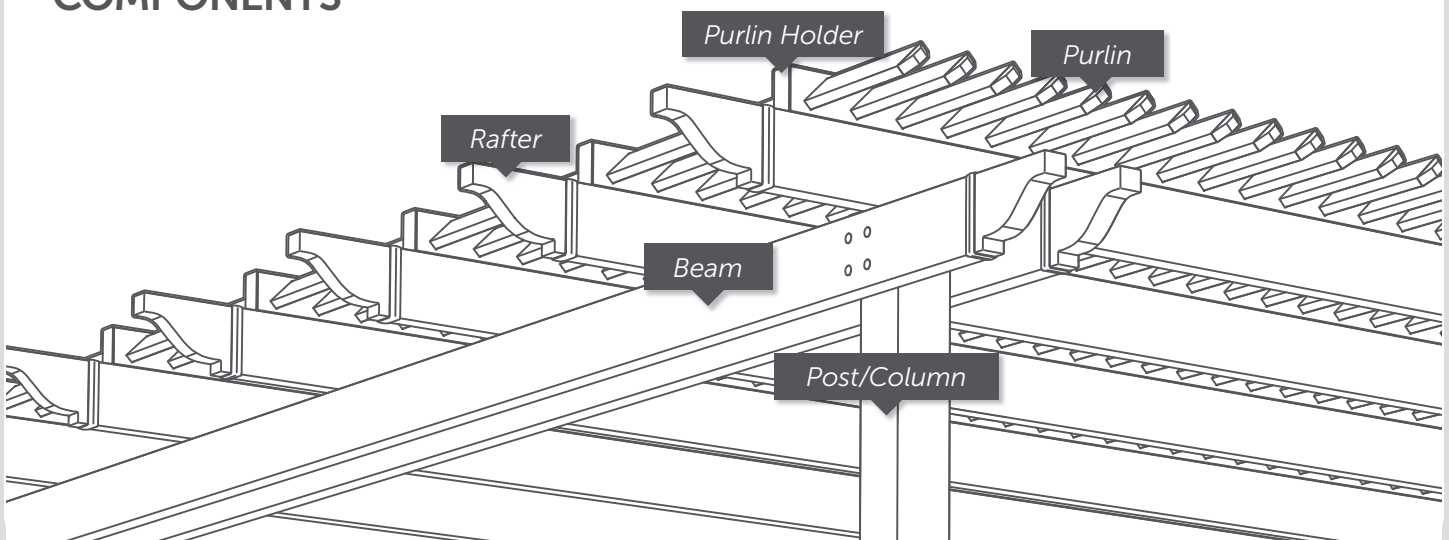

STEP 1

LAYOUT

A NOTE ON PERGOLA SIZES

Sizes are defined by the total width and depth of the roof. For example, a 12' x 16' pergola will have a roof area of 12' x 16' and a post spacing of 10' x 14'.

ALL PERGOLA KITS CAN BE CUT TO SIZE.

The beams and rafters supplied in the kit are NOT pre-drilled. This is to allow the width and depth to be customizable for each kit. Our standard sizes are designed around a 1' overhang on each end. This is merely a rule of thumb and can be adjusted during installation.

View CAD drawings and photos of installed pergolas at Heartlandpergolas.com

MEASURE

- a. Determine necessary height, post locations and overhangs based upon site – Make note of the following measurements as you will want these later:
 1. Desired outside to outside dimensions of your posts
 2. Desired height to the top of your beam (same as height to bottom of your rafter)
- b. Ensure posts are square with each other and/or any adjoining structure
 1. Post and beam spacing is adjustable to fit installation site and any obstructions. Beam and rafter overhangs should not exceed 36", purlins should not exceed 24".
 2. **NOTE:** If adding to existing slab or patio do not assume that they are built square!
- c. It is common that existing concrete and paver patios are installed with a certain degree of slope. If slope is minimal (less than 1" in 10') you can simply disregard it. If slope is more pronounced, consider that your posts may be differing lengths to allow pergola roof to be level to horizon.
- d. Maximum span of 2x6 beams and rafters is 16'. 2x8 beams and rafters can span 22'
- e. Note that purlin holders do not have to run under any roof overhangs on your site. This allows maximum head clearance for your rafters.
- f. For challenging sites, custom fabrication of pergolas to your unique site is available, please contact [us].

EXAMPLE:

If you have a patio that is 10'-6" deep x 13' wide you would want a roof that was at least 12'-6" deep x 15' wide. You would order the next size up, a 14' deep x 16' wide and trim the beams and rafters to your desired overhang.

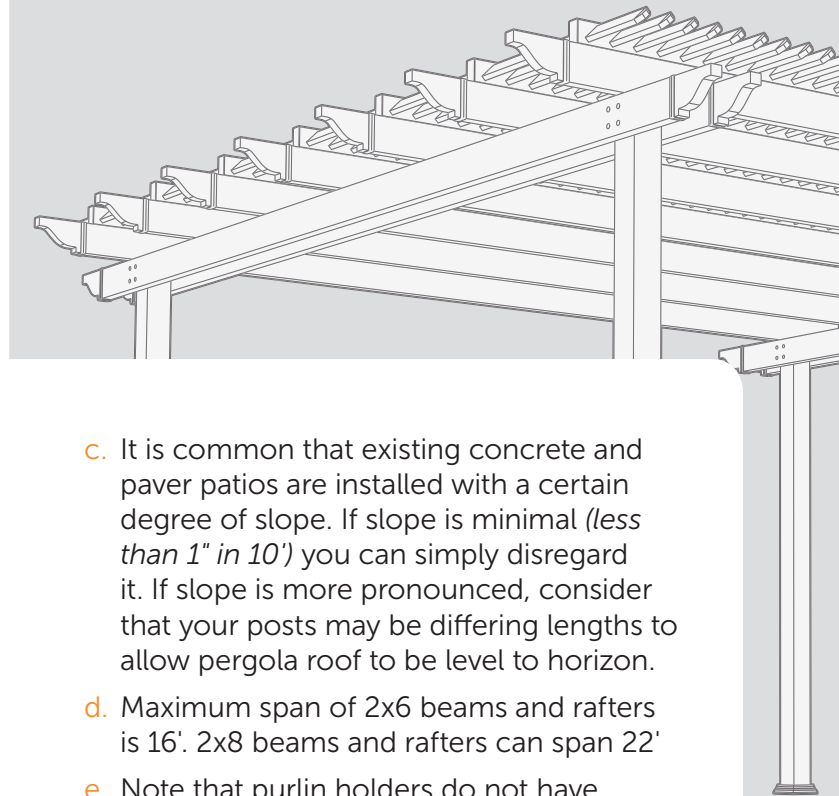

STEP 2

INSTALL POST MOUNTS

2A MOUNT TO DECK

- a. Add blocking below deck flooring under each post mount. Minimum blocking thickness of 3" (*this is two 2x10's thick*)
- b. Inset mount as necessary to ensure post skirt does not overhang edge of decking
 - Minimum 6.25" inset from edge to center of mount for a 10" round column
 - Minimum 5.25" inset from edge to center of mount for a 7" square or 7" round column
 - Minimum 3.25" inset from edge to center of mount for 5x5 post
- c. Detail on nailing blocking – Minimum 4 nails on each side of 2by block
- d. Mount Fasteners – Carriage Bolts or ledger attachment screw (*5" Recommended*)
- e. Use composite shims as necessary to plumb mount. Tighten fasteners.

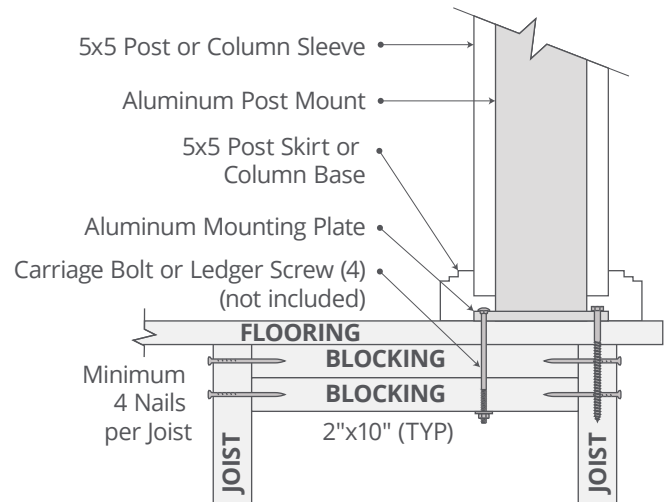

2B MOUNT TO SLAB OR LANDSCAPE COLUMN TOP

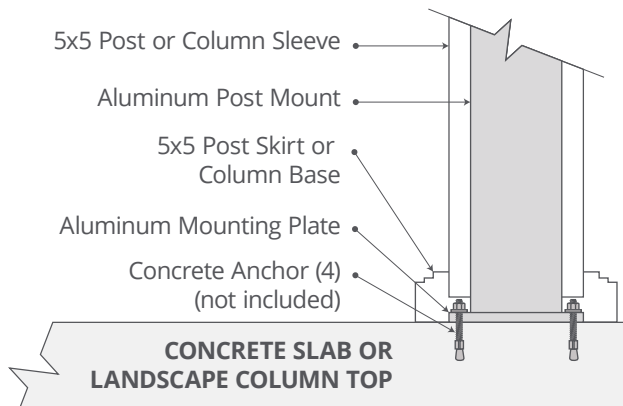

- a. Inset mount as necessary to ensure post skirt does not overhang edge of slab or column top
 - Minimum 6.25" inset from edge to center of mount for a 10" round column
 - Minimum 5.25" inset from edge to center of mount for a 7" square or 7" round column
 - Minimum 3.25" inset from edge to center of mount for 5x5 post
- b. Mount Fasteners - $\frac{3}{8}$ " hot dipped galvanized wedge or screw type anchors minimum 4" embedment.
- c. Use composite shims as necessary to plumb mount. Tighten anchors.

NOTE:

FOR A POURED SLAB, concrete must be a minimum 4" thick.

FOR A LANDSCAPE COLUMN we recommend a one-piece cap of concrete or natural stone (4000 psi or greater).

It is important that the column is constructed on a sound foundation. For a compacted gravel base, this means minimum two courses below grade, for a concrete base, be sure to attach footing to base course with plenty of landscape adhesive. For construction of column we recommend either masonry or a high quality concrete product installed with plenty of landscape adhesive. In the case of adhesive, more is usually better. In windy areas we have even had customers fill the pillar(s) with concrete to add weight and rigidity.

2C MOUNT TO FOOTING – 10" ROUND, 7" ROUND, OR 7" SQUARE COLUMN

a. The main goal in this method is to isolate the pergola posts from the patio area without looking like it. This allows the patio to move up and down over the seasons while the pergola posts stay rock solid. To do this properly you need to make sure you know the finished grade of the patio.

- If there is an existing patio, you can simply remove blocks as necessary to form and pour footings to the height of the existing patio surface. Use a concrete saw to cut the paver blocks to fit around the column once the forms are removed.
- If the patio is not yet installed, you **MUST** establish the desired patio surface height prior to forming and pouring your footings. The end goal is that the patio block will fit neatly around the column base without fitting under it. This allows the patio to freely move up and down without squeezing or crushing parts of the pergola column.

NOTE: It is common that the patio will have some slope. This is no problem. Simply set the top of your forms to follow the desired slope. The roof of the pergola can still be installed level.

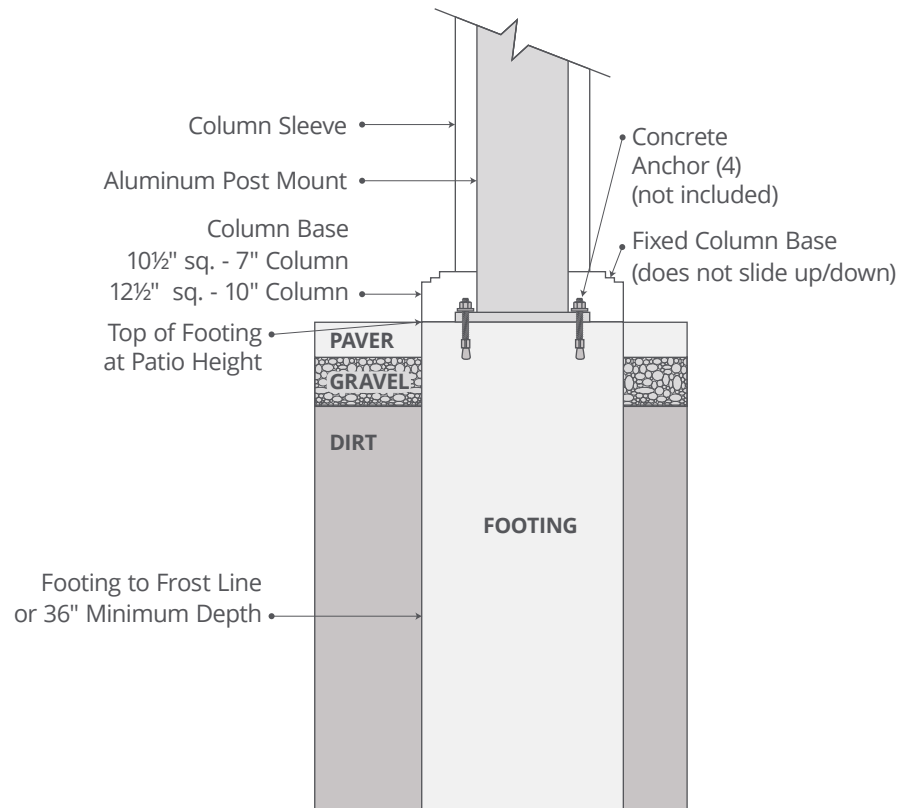

- b. Determine post locations and layout with strings and tape measures.
- c. Minimum footing size = 12" round - with top 4" of footing formed to match the size of column base (see sizes above). Note: Column bases are fixed and do not slide up and down the post.
- d. Dig footings to frost line, making sure to remove excess loose dirt from the bottom of the hole.
- e. Build, stake and level forms over your holes. Ensure your

forms are installed square to patio or structure. It is often helpful to set string lines to double check the locations as well as desired height of the footings.

- f. Fill holes with concrete to top of forms and trowel smooth
- g. Once cured, attach post mounts to footings using $\frac{3}{8}$ " dia. hot dipped galvanized wedge or screw type anchors, minimum 4" embedment. Use composite shims as necessary to plumb mount. Tighten anchors.

2D MOUNT IN FOOTING (5X5 POST)

- a. The 5x5 post comes with a movable post skirt and (*optional*) trim ring. These can slide up or down the post and allow you to finish your patio height at any level and simply slide the skirt down to meet the finished surface. Because the trim will move up and down with ease, you can set your posts and build your patio around them. Make sure to leave the top of your footings low enough that they do not interfere with the patio being installed around them.
- b. Dig a 12" round footing to frost depth making sure to clean any loose dirt from the bottom of your hole.
- c. Fill holes with concrete to top of forms and trowel smooth
- d. Once cured, attach post mounts to footings using $\frac{3}{8}$ " dia. hot dipped galvanized wedge or screw type anchors, minimum 4" embedment. Use composite shims as necessary to plumb mount. Tighten anchors.

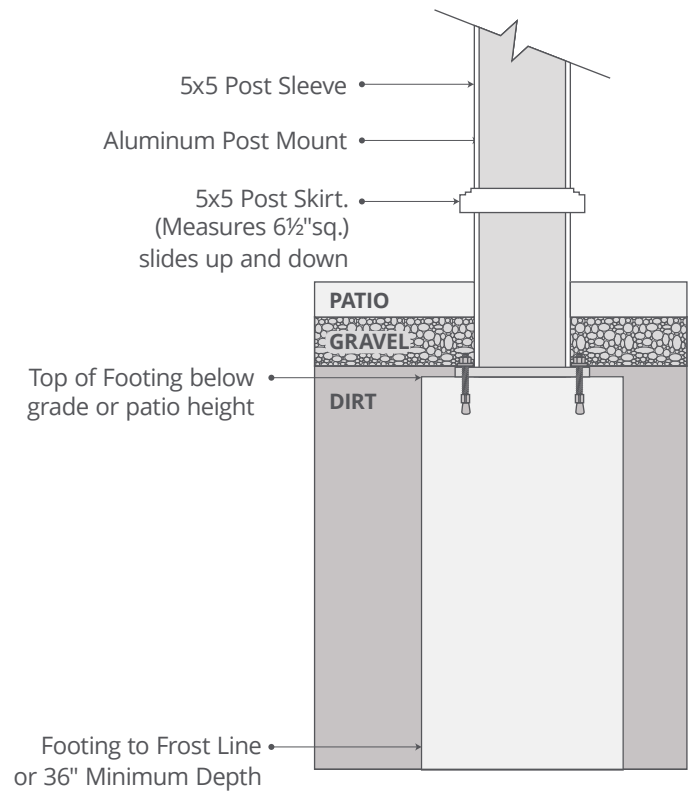

NOTE:

This type of footing is best when building pergola in conjunction with a paver patio or a concrete patio that is less than 4" thick. This is also the best application if you have any concerns of frost heaving the patio.

STEP 3

INSTALL COLUMNS OVER POST MOUNT

CUT POST MOUNT TO HEIGHT

- a. Mark the desired top of beam height on each post mount.
 - Ensure the top of beam will be level. The simplest way (short of using a laser level) is to quick clamp your beams to your post mounts and adjust until level.
- b. Measure the distance from the ground to this mark on each post.

Write these measurements here:

Post A _____

Post B _____

Post C _____

Post D _____

- c. Cut each aluminum post mount 1" below recorded measurements above.
- d. Drop wood post plug into top of each post mount.
 - This provides a more solid beam to post connection.

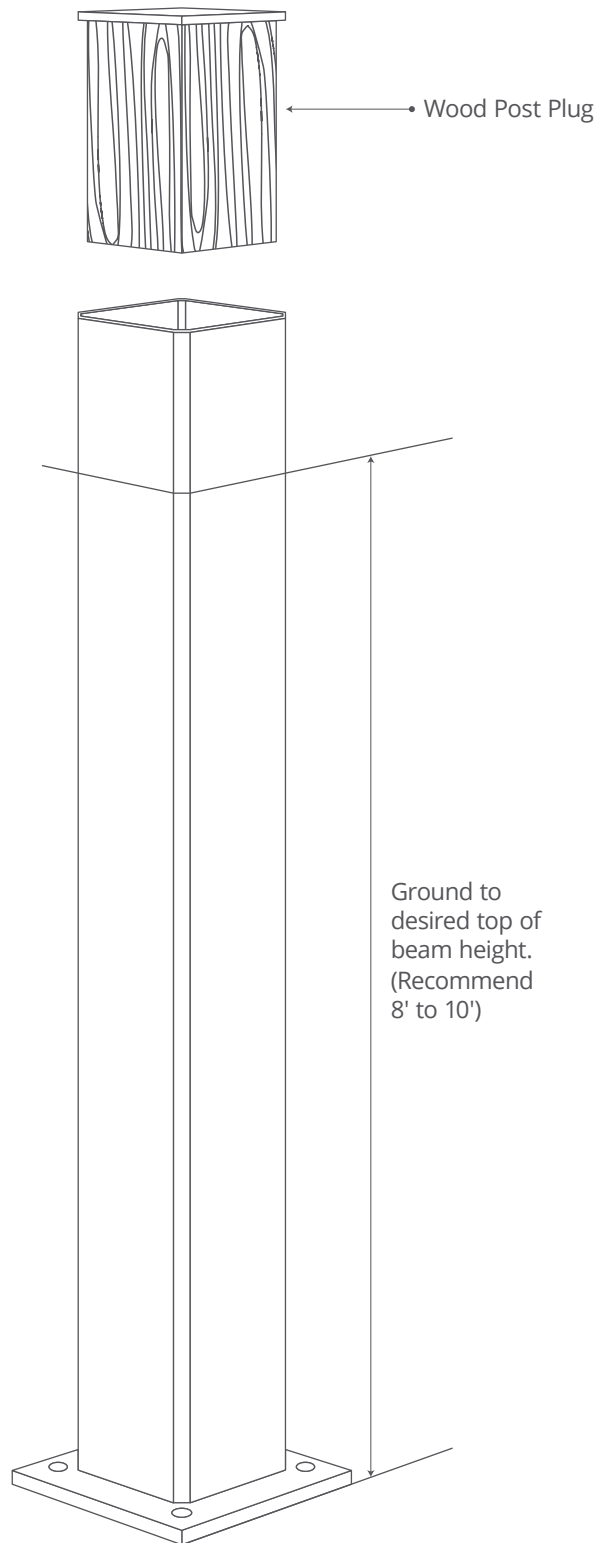
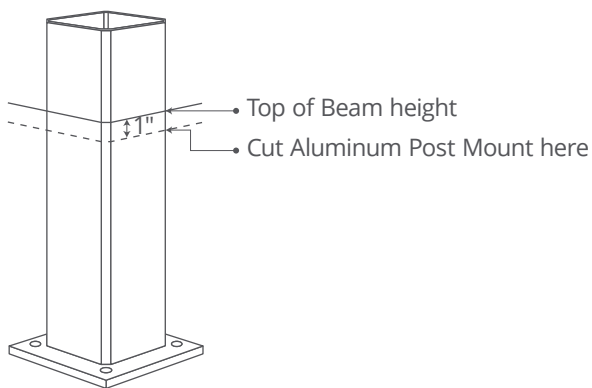

3A INSTALL 5" X 5" POST OVER POST MOUNT

- Cut each 5x5 vinyl post sleeve to proper height.
 - Cut post $\frac{1}{2}$ " shorter than recorded measurements.
- Install skirts and optional trim rings on to your vinyl post sleeve, these fit tight.
- Slide vinyl post over the top of the aluminum post mount.
 - Your vinyl post should stick up 1" taller than the top of the aluminum mount to allow room for pyramid post cap.

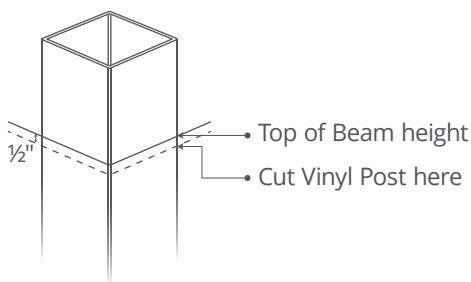

3B INSTALL COLUMN OVER POST MOUNT (7" SQUARE/ 7" ROUND/10" ROUND COLUMN)

- Cut each vinyl column sleeve to proper height:
 - Kits with a 6" beam: Cut column 8" shorter than recorded measurements.
 - Kits with an 8" beam: Cut column 10" shorter than recorded measurements.
- Slide column base, sleeve, and cap over post mount (in that order), these fit tight.
- Slide the 5" x 5" vinyl post cover with cap over the aluminum post mount.
 - This slides through the hole in the top of the column cap.
- Secure column base to a deck with wood deck screws; to a footing or slab with small concrete screws (Tapcons® or similar)

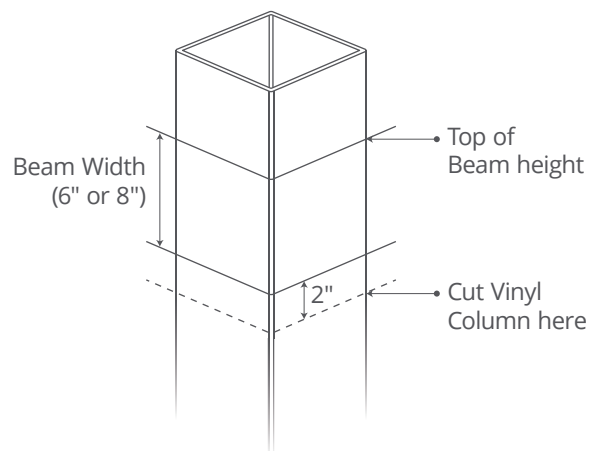

STEP 4

ATTACH LEDGER TO STRUCTURE [ATTACHED PERGOLAS ONLY]

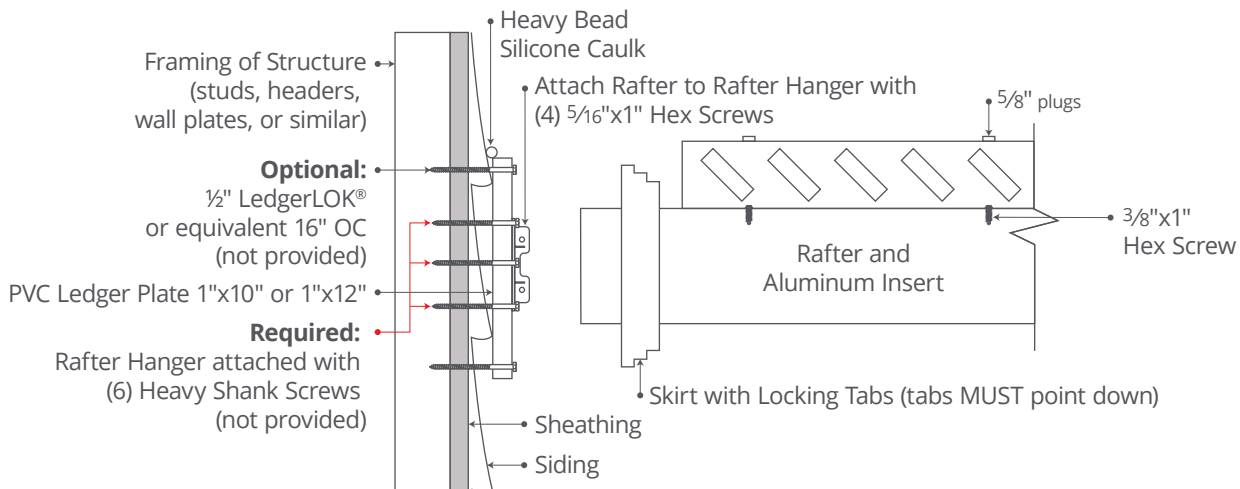

- Secure ledger to structure ensuring it is centered on pergola –
PRO TIP: layout and mark rafter hanger locations prior to installation of ledger plate.
- Fasteners – Necessary fasteners for Ledger are NOT provided in kit. Requirements determined by structure.
- Minimum height for rafter attachment without modification:
 - 2x6 Rafter - skirt is 7 1/2" tall, 1"x10" Azek Trim Ledger Plate is 3/4" thick x 9 1/4" tall
 - 2x8 Rafter – skirt is 9 1/2" tall, 1"x12" Azek Trim Ledger Plate is 3/4" thick x 11 1/4" tall
 - NOTE:** for a tight spot you can trim PVC ledger Plate or rafter skirt to reduce the overall height of rafter attachment.
- Attach rafter hangers based on your layout measurements.

NOTE:

If removing siding, ensure that ledger plate is properly flashed and sealed.

If ledger is installed over top of siding, ensure that top and sides are caulked adequately.

STEP 5

INSTALL BEAMS

BEAM ATTACHMENT TO POST

PRO TIPS:

If flat caps are desired on ends of a beam, cut aluminum insert short by 1/2" per end to allow for insert of cap.

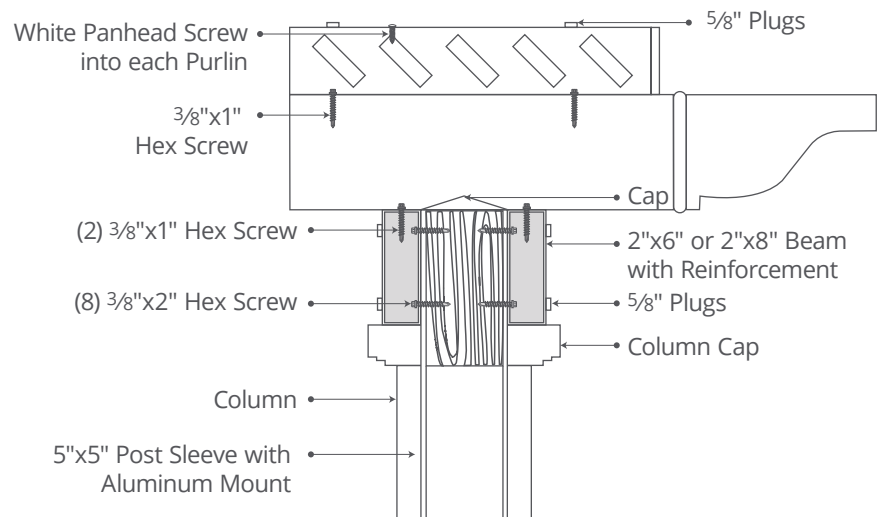

There are two methods of attaching a beam to the post:

- a. **TRADITIONAL METHOD** - use the template provided with each kit to mark and drill a 4-hole pattern for each beam to post attachment location and screw beam to post with fasteners provided. Holes in beam are then covered with plugs.
- b. **BEAM ATTACHMENT BRACKETS** - These brackets are powder coated stainless steel and are installed with matching self-drilling screws. They are an additional option on each kit add slightly to the cost. The benefit is that these brackets eliminate the need to pre-drill the 4-hole pattern for each beam

to post attachment. This saves installation time and makes for a slightly more DIY friendly installation.

TRADITIONAL METHOD

- a. Determine desired beam length and overhangs. Trim beams if necessary.
- b. Mark and drill **OUTSIDE FACE ONLY** of beam and aluminum insert with 5/8" diameter bit. Four holes per beam connection. **NOTE:** Ream holes larger in ALUMINUM ONLY for easier plug installation.
- c. Attach beam to post with provided heavy 3/8" x 2" hex screws and cover with 5/8" plugs.

BEAM ATTACHMENT BRACKETS

- a. Determine desired beam length and overhangs. Trim beams if necessary.
- b. Secure first beam to top of post with a clamp. Fasten beam attachment brackets with provided fasteners. **IMPORTANT:** The shorter fasteners go into the beam; the longer fasteners go into the post.
- c. On second beam, measure and mark location of beam attachment bracket.
- d. Install beam attachment bracket to beam.
- e. Raise beam into place and attach beam attachment bracket to post.

STEP 6

RAFTER ATTACHMENT

TRADITIONAL METHOD:

Drill and Screw through face of beam

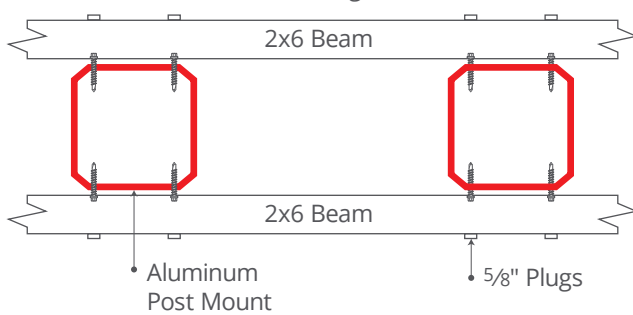

BEAM ATTACHMENT BRACKETS:

No pre-drilling through Face of Beam

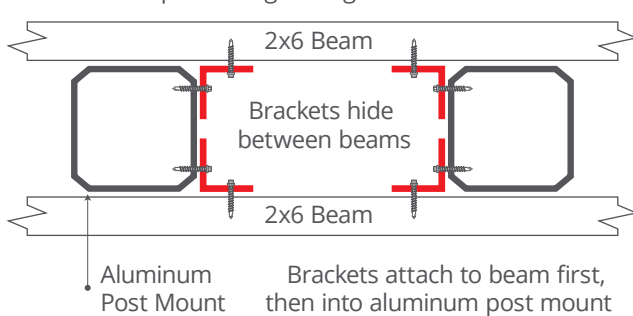

6A ATTACH RAFTERS TO BEAM

- Set rafter on top of beam with desired overhang. Trim rafters if necessary. Mark hole locations directly above each beam.
- Drill through TOP ONLY of rafter with step bit, directly over center of both beams – This is safest to do on sawhorses at ground level.

Attach rafter to each beam with $\frac{3}{8}$ " x 1" hex screws.

6B ATTACH RAFTERS TO LEDGER [ATTACHED PERGOLAS ONLY]

- Install rafter hangers to ledger plate per desired layout.
- Slide rafter hanger skirt over rafter. Note: Skirts are directional and need to be slid on with the four locking tabs in the downward direction.
- Attach rafter to hanger with $\frac{5}{16}$ " x 1" hex screws ensuring that screws penetrate aluminum insert.
- Slide skirt to cover hanger bracket.
- PRO-TIP:** If structural wall is bowed, adjust rafter length as necessary to ensure uniform overhang over beam.

PRO TIPS:

If pergola is attached to a structure always attach rafters to ledger before securing them to the beam.

If flat caps are desired on ends of a rafter cut aluminum insert short by $\frac{1}{2}$ " per end to allow for insert of flat cap.

STEP 7

ATTACH PURLIN HOLDERS

- a. For maximum shade, determine primary direction of sun and install purlin holders to angle purlins accordingly.
- b. Determine desired length of purlin holders. Note: holders must be held back a minimum of 1 ½" from end of rafter to allow installation of curved rafter end cap.
- c. If necessary, cut purlin holders to desired length, ensuring that you cut between holes.
- d. **PRO-TIP:** For easiest purlin installation make sure that holes in purlin holders line up. This is what the string line in the tool list is for. Install the two outside purlin holders and run a tight string between them. Place all other purlin holders almost touching string. **DO NOT** depend on rafters or face of your structure to be perfectly in line.
- e. Using provided 5/8" holes screw holders to rafter with 3/8" x 1" hex screws. If purlin holder was cut down it may be necessary to drill a new 5/8" mounting hole.
- f. Plug holes with 5/8" plugs.

STEP 8

INSTALL PURLINS

- a. If necessary, measure and cut purlins to desired length.
- b. **PRO-TIP:** Purlin overhang from holder should not exceed 24".
- c. Install cap on both ends of purlins. These caps help guide purlins through the holes and make purlin installation MUCH simpler.
- d. Slide purlins into secured holders ensuring that the ends have a uniform overhang.
- e. Fasten purlins through top of purlin holder with tan or white 1 ½" phillips pan head screws.
- f. **PRO-TIP:** It is only necessary to screw purlins through one holder as long as purlins have not been cut or spliced.
- g. **PRO-TIP:** If it is necessary to splice a purlin, measure and cut to allow for the splice in the center of the purlin holder; this is the best area to screw the purlins, as any extreme cold temperatures will not pull the splice apart.

STEP 9

CAPS AND FINISHING

- a. Glue on beam and rafter end caps.
- b. Glue in plugs for column bases.
- c. Wipe off any construction marks.
- d. **PRO-TIP:** Window cleaner and Mr. Clean Magic Erasers® work excellent on any hard to remove marks.

STEP 10

ENJOY THE SHADE!

FAN MOUNT ACCESSORIES

PARTS OVERVIEW

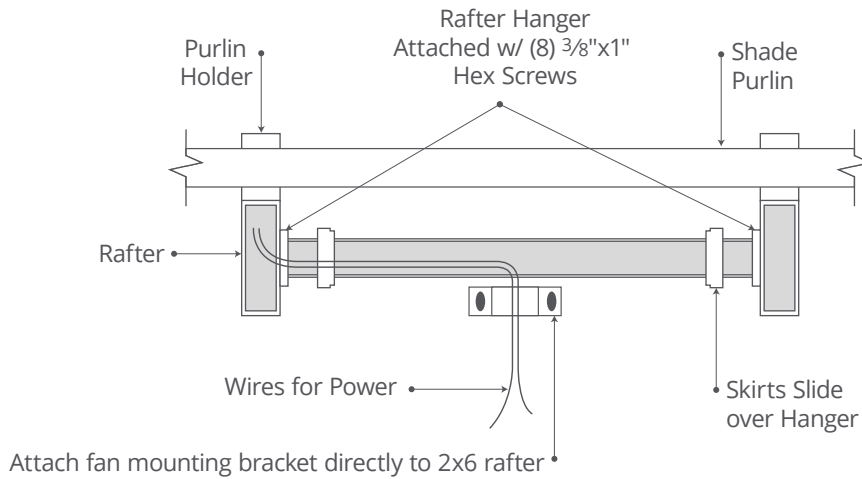

STEP 1: ATTACH HANGERS

ZOOMED OUT

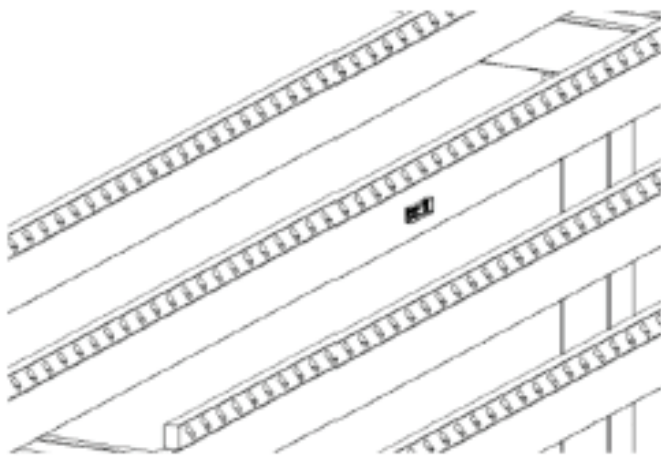

- Center your hangers on your 2x6 or 2x8 rafter profile.
- **NOTE:** Place your hanger within one inch of your self-made wiring hole.

ZOOMED IN

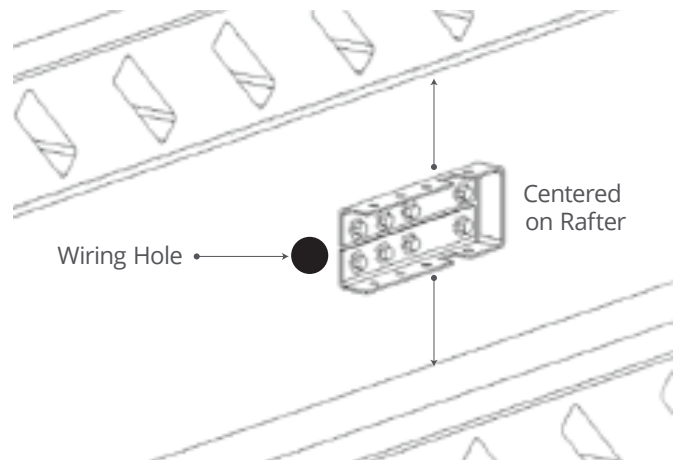

- Fasten each hanger using (8) 3/8" x 1" hex screws provided in your fan kit
- Ensure both hanger openings are pointing the same direction for sliding your 2x8 fan mount profile into the hangers.

NOTE: The metal bracket is only 6" long for your 2x8 fan mount. This is done on purpose to allow for your wiring hole to be covered up by your vinyl trim ring shown in Step 3.

STEP 2: TRIM 2X8 PROFILE

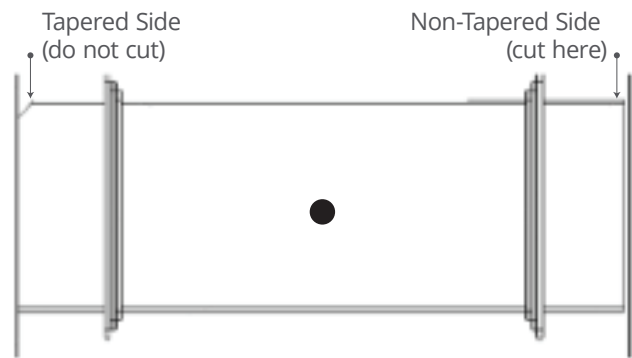
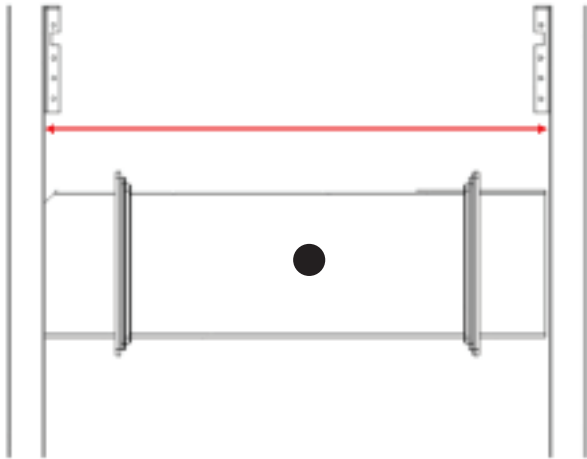

- Make a hole on the bottom side of the 2x8 profile to pull wire through.
- Measure the distance from inside-to-inside of your rafter hangers. Ignore fastener heads.

- Cut the **non-tapered** side of the 2x8 fan mount profile 1/4" shorter than your measurement.
- **EXAMPLE:** *Inside-to-inside measurement of hangers is 28". Cut your 2x8 profile to 27 3/4".*

STEP 3: SECURE FAN MOUNT

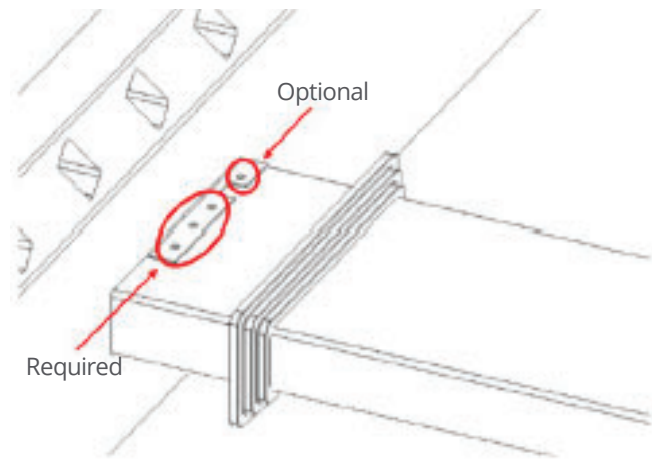
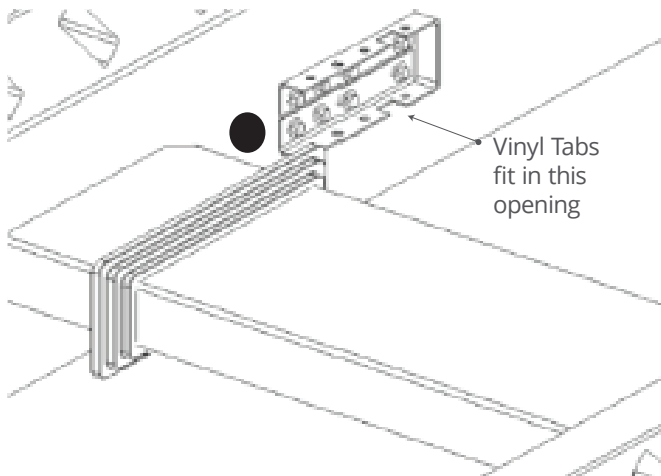

- Slide your vinyl trim rings over your 2x8 profile as pictured. Ensure the "tabs" on the inside of the vinyl trim rings line up with the holes on the metal bracket openings.

- Pull your wire through the hole made in the 2x8 and then slide the 2x8 into the hangers. Fasten with 3/8" x 1" hex screws. Slide rings over brackets.
- **NOTE:** *The six middle holes are required fasteners and the two outside holes are optional.*

HURRICANE CLIPS

ACCESSORIES

OPTIONAL

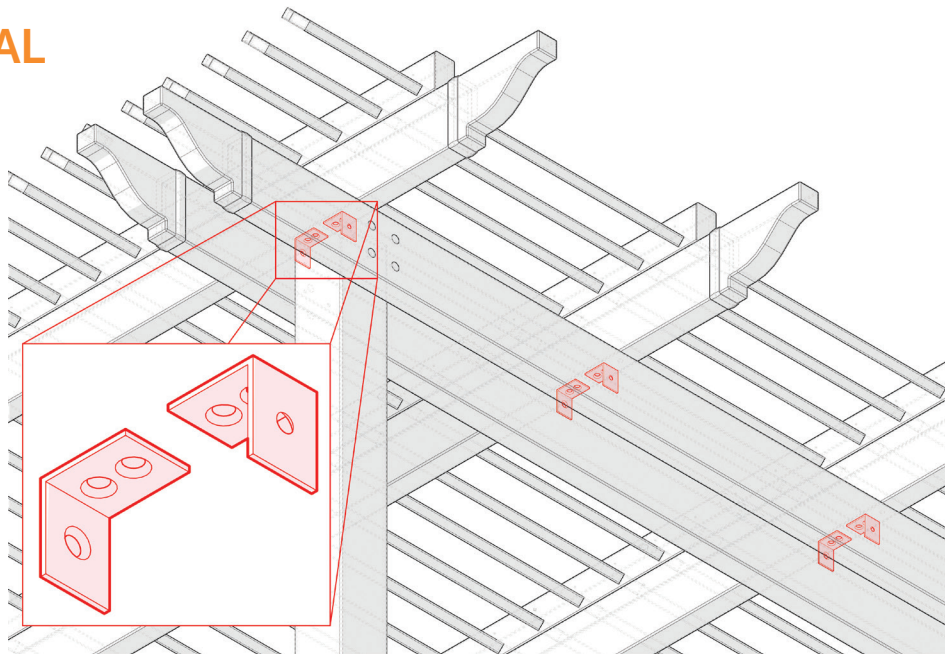

These clips, when installed properly, dramatically increase your pergola's uplift resistance under extreme wind loads. Refer to your warranty for more information regarding our residential lifetime wind warranty.

Clips are designed to be installed at each rafter to beam intersection in one of three ways:

1. On the inside of the double beam (*as shown in diagram, least visible*)
2. On top of the beam (*works well when a post or column is in the way*)
3. On the outside of the beam (*most visible, not recommended*)

The screws provided are self-drilling. Along with the right angle drill attachment (*provided with hurricane clip kit*), this makes installation on the inside of the beams easy.

- a. Hold the clip in the desired place, in between the beams and under the rafter.
- b. Install two screws into the underside of the rafter.
- c. Attach the right angle drill adaptor.
- d. Install two screws through the clip into the beam.
- e. Repeat at each rafter and beam intersection.
- f. Where a post or other obstruction prevents attachment in between the beams, mount the clip on top of the beam and into the side of the rafter.